

IDEAS GENERATED DRAWING, DON'T CHANGE BY HAND.

| REV. | ECN. NO.      | APPD.      |
|------|---------------|------------|
| A    | BC-08-7081973 | Herry Yang |
| B    | BC-09-7108234 | Herry Yang |
| C    | BC-11-0024706 | Herry Yang |
| D    | BC-13-0086293 | C.S Li     |
| E    | BC-17-0042095 | Davy Bu    |
| F    | BC-18-0009439 | Davy Bu    |

NOTES:

1. ELECTRICAL CHARACTERISTICS :
  - 1.1 VOLTAGE RATING 50V DC PER CONTACT.
  - 1.2 INSULATION RESISTANCE : 250MEGAOHMS. MIN. AT 500V DC.
2. MECHANICAL CHARACTERISTICS :
  - 2.1 DURABILITY : 60 MATING CYCLES.
3. OPERATION TEMPERATURE : -40°C TO + 85°C
4. THE NVIDIA'S MOBILE PCI EXPRESS MODULE ELECTROMECHANICAL SPECIFICATION CONTROLS MXM GRAPHICS MODULE PCB AND CONNECTOR MOTHERBOARD FOOTPRINT DIMENSIONS. IT IS SHOWN FOR REFERENCE ONLY, AND IS SUBJECT TO CHANGE.
5. INTERPRET DRAWING PER ASME Y14.5M-1994.
6. PLEASE CONTACT FOXCONN SALES REPRESENTATIVE TO VERIFY PRODUCT DETAILS & AVAILABILITY.

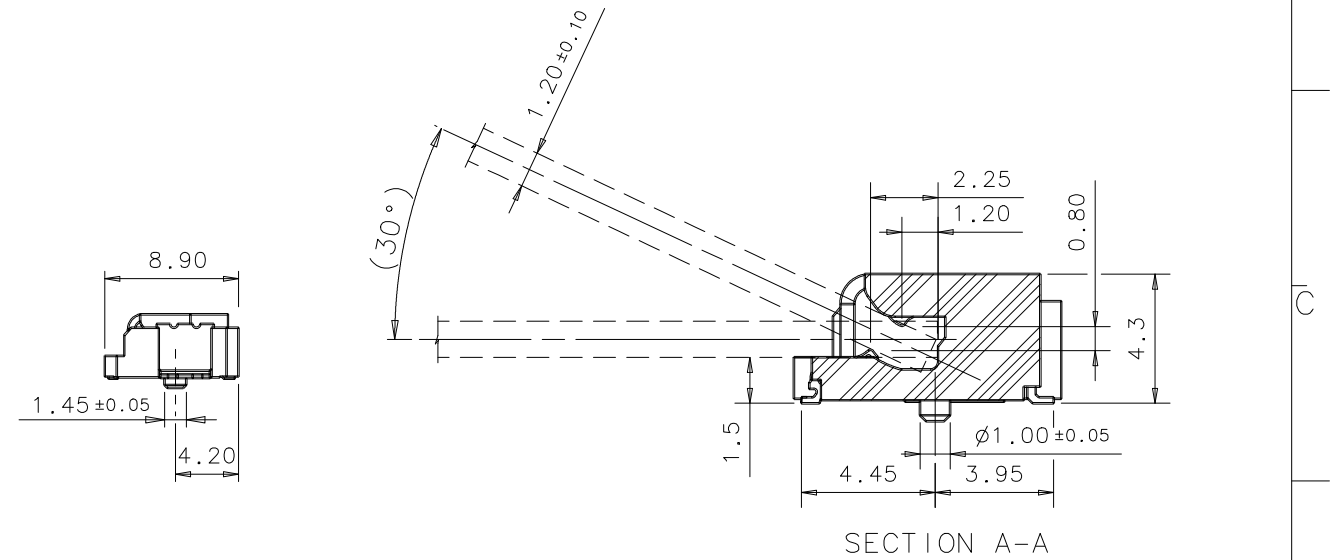
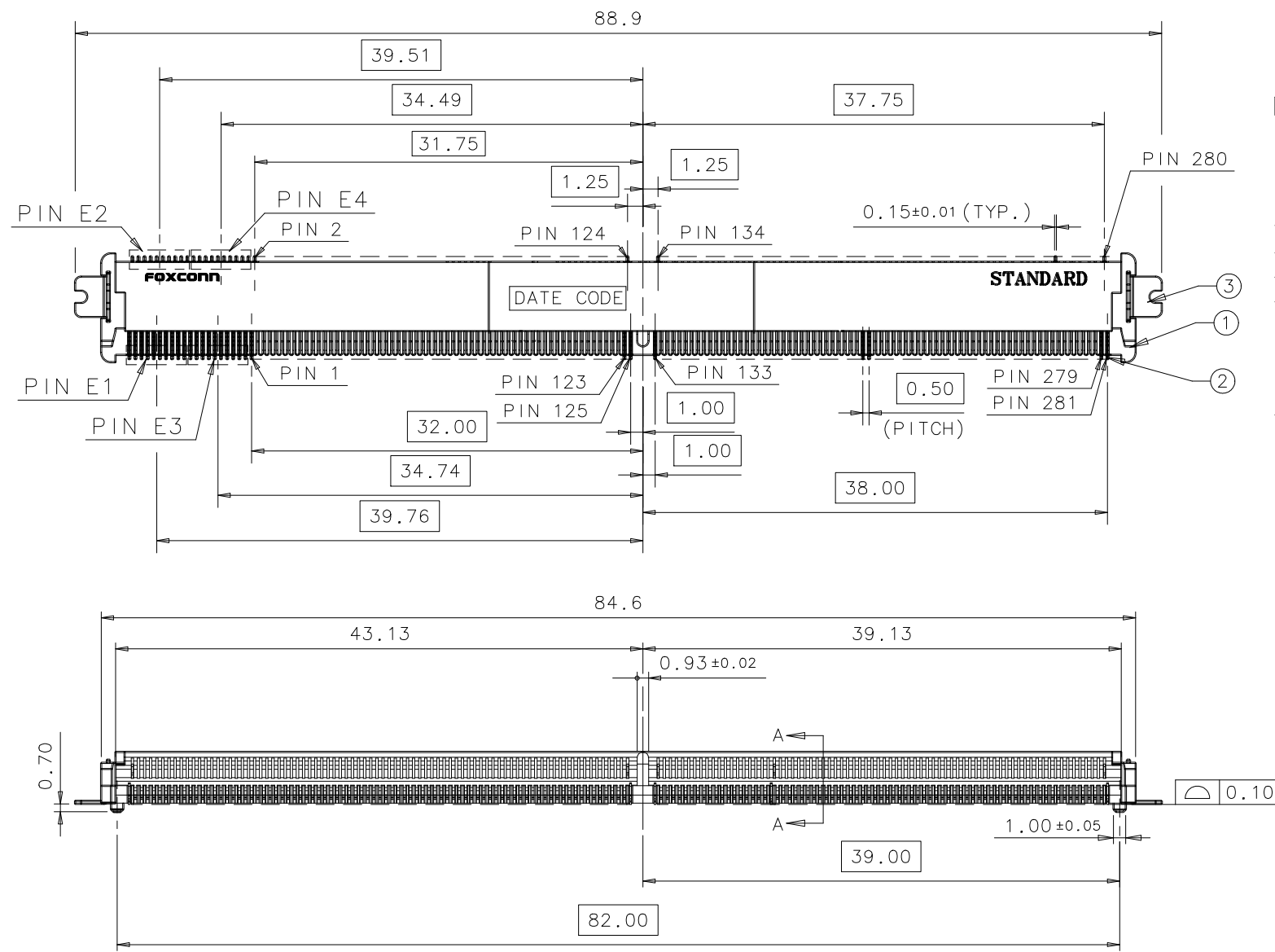

PART NO. DESCRIPTION: A S O B8 2 \* - S 43 \* - \* H

MEMORY MODULE SOCKET  
 HORIZONTAL TYPE  
 SINGLE ROW  
 NO. OF POS.  
 B8= 314 POS.  
 SMT  
 CONTACT AREA PLATING  
 1=GOLD FLASH  
 Y=5u" GOLD PLATING  
 6=10u" GOLD PLATING  
 7=15u" GOLD PLATING  
 3=30u" GOLD PLATING

H=HALOGEN/LEAD FREE  
 7=TAPE & REEL  
 4=SOFT TRAY  
 B=BLACK COLOR  
 N=IVORY COLOR  
 43=4.3mm HEIGHT  
 STANDARD

| ITEM | DESCRIPTION | Q'TY | MATERIAL      | TREATMENT   |
|------|-------------|------|---------------|---|
| ③    | METAL EAR   | 2    | COPPER ALLOY  | 50u" NICKLE UNDER PLATING OVER ALL<br>30u" PURE TIN PLATING OVER ALL  |
| ②    | CONTACT     | 314  | COPPER ALLOY  | 50u" NICKEL UNDER PLATING<br>GOLD FLASH AT TAIL<br>GOLD FLASH OR 5u" GOLD PLATING OR 10u" GOLD PLATING<br>OR 15u" GOLD PLATING OR 30u" GOLD PLATING AT CONTACT AREA |
| ①    | HOUSING     | 1    | THERMOPLASTIC | UL94V-0, HALOGEN FREE   |

| UNITS   | mm         | NAME (INTENDED USE)     | FOXCONN INTERCONNECT TECHNOLOGY LIMITED.  |
|---|------------|-------------------------|---|
| X. ± 0.30   | X° ± 2.0°  | MXM 3.0 CONNECTOR       |   |
| .X ± 0.20   | .X° ± 1.0° | PART NO. (INTENDED USE) |   |
| .XX ± 0.15  | .XX°       | ASOB82*-S43*-*H         |   |
| .XXX±   | .XXX°±     | FINISH                  | CLASS:<br><input type="checkbox"/> CONFIDENTIAL <input type="checkbox"/> SECRET <input checked="" type="checkbox"/> GENERAL |
| THESE DRAWINGS AND SPECIFICATIONS ARE THE PROPERTY OF FOXCONN INTERCONNECT TECHNOLOGY LIMITED AND SHALL NOT BE REPRODUCED, COPIED OR USED IN ANY MANNER WITHOUT THE PRIOR WRITTEN CONSENT OF FOXCONN INTERCONNECT TECHNOLOGY LIMITED. |            |                         | TITLE: CUSTOMER DRAWING   |
| Q'TY  |            |                         | DWG NO.:  |
|   |            |                         | 317-0000-1659   |
| APPD: Davy Bu   |            |                         | CHKD: Johnny Tang   |
| DR: Eric.y.s 03/01'18   |            |                         | SCALE SHEET REV.  |
|   |            |                         | N/A 1/4 F   |

IDEAS GENERATED DRAWING, DON'T CHANGE BY HAND.

|      |          |       |
|------|----------|-------|
| REV. | ECN. NO. | APPD. |
|      |          |       |

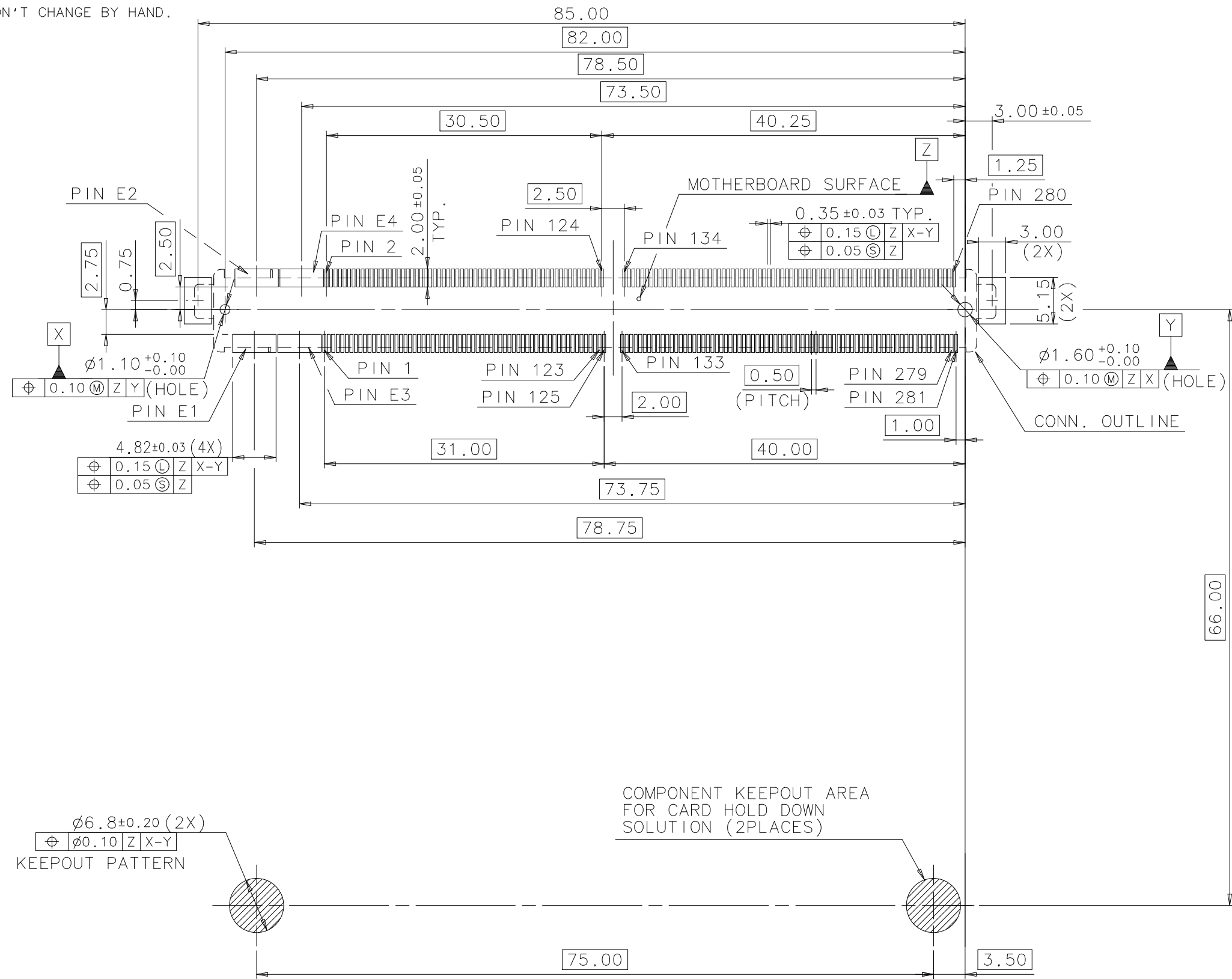

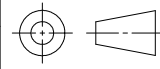
|  |            |          |   |   |
|--|------------|----------|---|---|
| X. ±   | X°. ± 2.0° | UNITS mm | NAME (INTENDED USE)<br>MXM 3.0 CONNECTOR  |  <b>FOXCONN INTERCONNECT TECHNOLOGY LIMITED.</b> |
| .X ± 0.10  | .X° ± 1.0° | MAT'L    | PART NO. (INTENDED USE)<br>AS0B82*-S43*-*H  |   |
| .XX ± 0.05   | .XX°       | FINISH   | APPD: Davy Bu   | CLASS:<br><input type="checkbox"/> CONFIDENTIAL <input type="checkbox"/> SECRET <input checked="" type="checkbox"/> GENERAL           |
| .XXX ±   | .XXX° ±    | Q'TY     | CHKD: Johnny Tang   | TITLE: CUSTOMER DRAWING   |
| <small>THESE DRAWINGS AND SPECIFICATIONS ARE THE PROPERTY OF FOXCONN INTERCONNECT TECHNOLOGY LIMITED AND SHALL NOT BE REPRODUCED, COPIED OR USED IN ANY MANNER WITHOUT THE PRIOR WRITTEN CONSENT OF FOXCONN INTERCONNECT TECHNOLOGY LIMITED.</small> |            |          | DR: Eric.y.s 03/01'18   | DWG NO.:<br>317-0000-1659   |
|  |            |          |  | SCALE SHEET REV.<br>N/A 2/4 F   |

IDEAS GENERATED DRAWING, DON'T CHANGE BY HAND.

|      |          |       |
|------|----------|-------|
| REV. | ECN. NO. | APPD. |
|      |          |       |

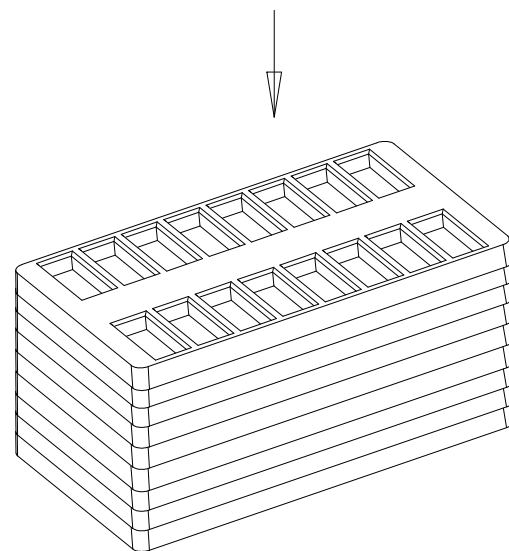
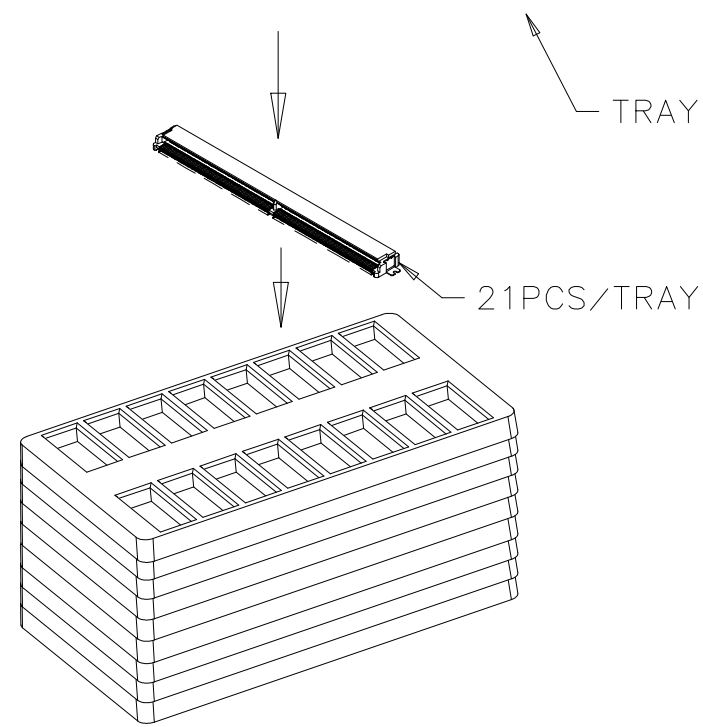
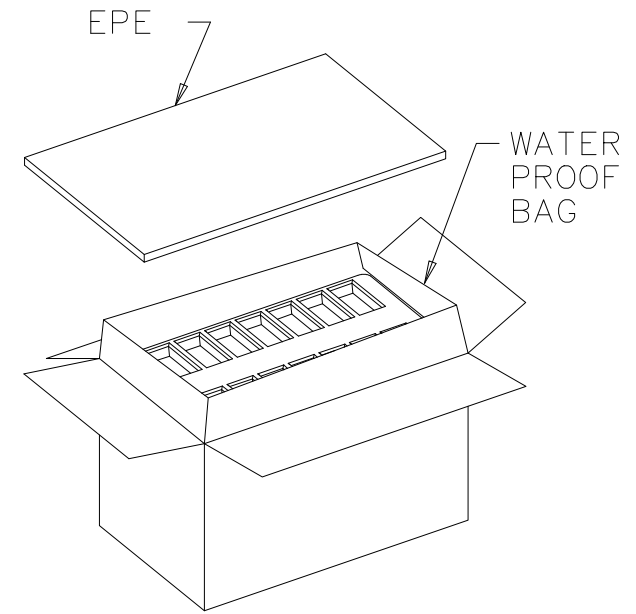
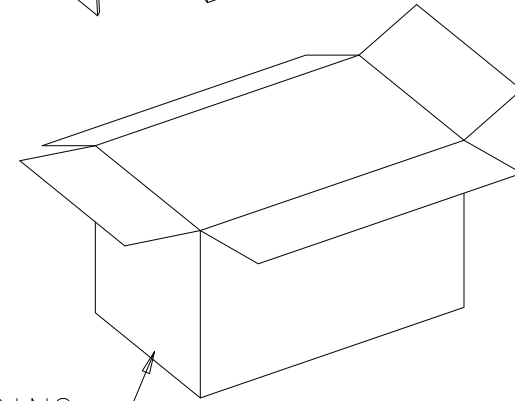
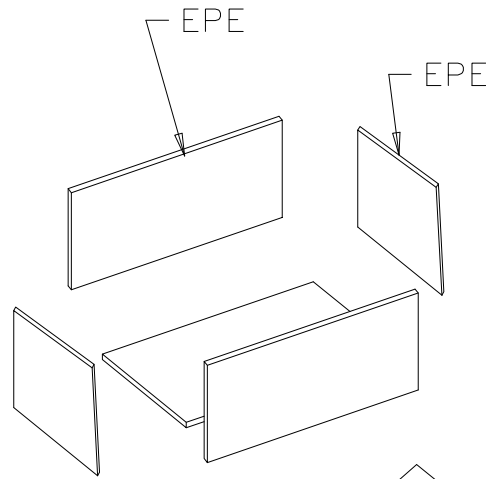
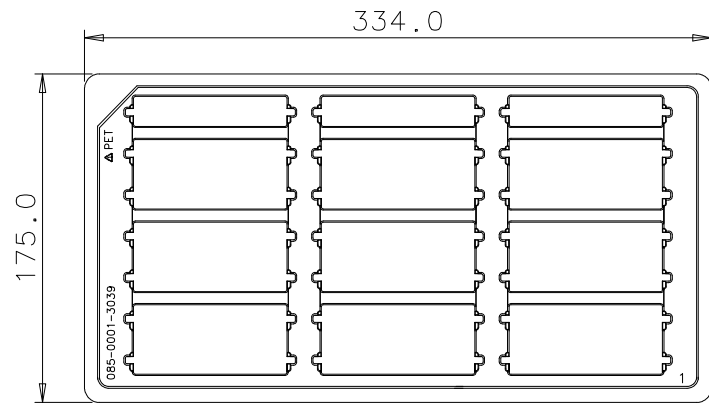

TOTAL 31 LAYERS TRAY  
THE TOP TRAY IS EMPTY

SHIPPING  
CARTON

TRANSPARENT  
SEAL TAPE

LABEL

|         |          |                 |
|---------|----------|-----------------|
| 630 PCS | 21 PCS   | ASOB82*-S43*-4H |
| QTY/BOX | QTY/TRAY | CONNECTOR P/N   |

|  |            |          |  |   |
|--|------------|----------|--|---|
| X. ±   | X°. ± 2.0° | UNITS mm | NAME (INTENDED USE)<br>MXM 3.0 CONNECTOR   | <b>FOXCONN INTERCONNECT TECHNOLOGY LIMITED.</b> |
| .X ± 1.0   | .X° ± 1.0° |          |  |   |
| .XX ± 0.50   | .XX°       | FINISH   | PART NO. (INTENDED USE)<br>ASOB82*-S43*-*H | TITLE: CUSTOMER DRAWING                         |
| .XXX±  | .XXX°±     |          | Q'TY                                       | APPD: Davy Bu                                   |
| <small>THESE DRAWINGS AND SPECIFICATIONS ARE THE PROPERTY OF FOXCONN INTERCONNECT TECHNOLOGY LIMITED AND SHALL NOT BE REPRODUCED, COPIED OR USED IN ANY MANNER WITHOUT THE PRIOR WRITTEN CONSENT OF FOXCONN INTERCONNECT TECHNOLOGY LIMITED.</small> |            |          | CHKD: Johnny Tang                          |   |
|  |            |          | DR: Eric.y.s 03/01'18                      |   |

IDEAS GENERATED DRAWING, DO NOT CHANGE BY HAND

|      |      |     |       |
|------|------|-----|-------|
| REV. | ECN. | NO. | APPD. |
|      |      |     |       |

FEEDING DIRECTION

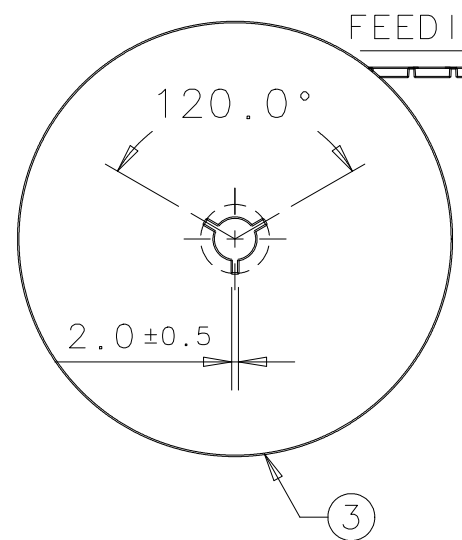
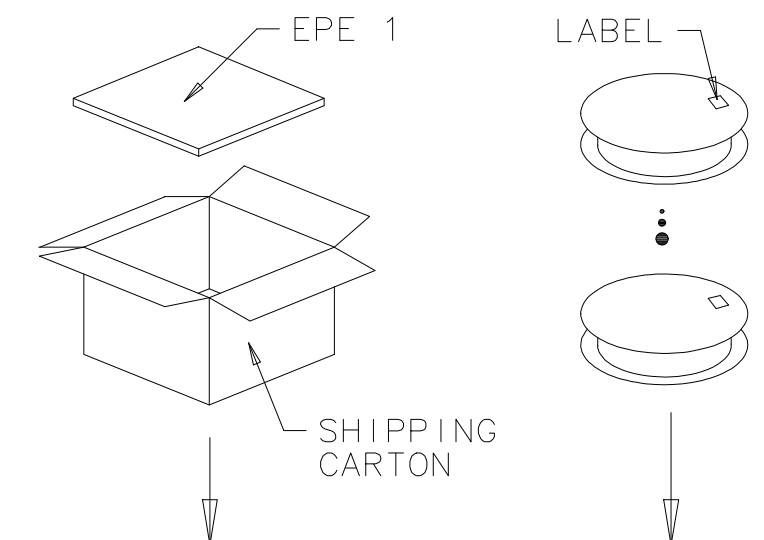
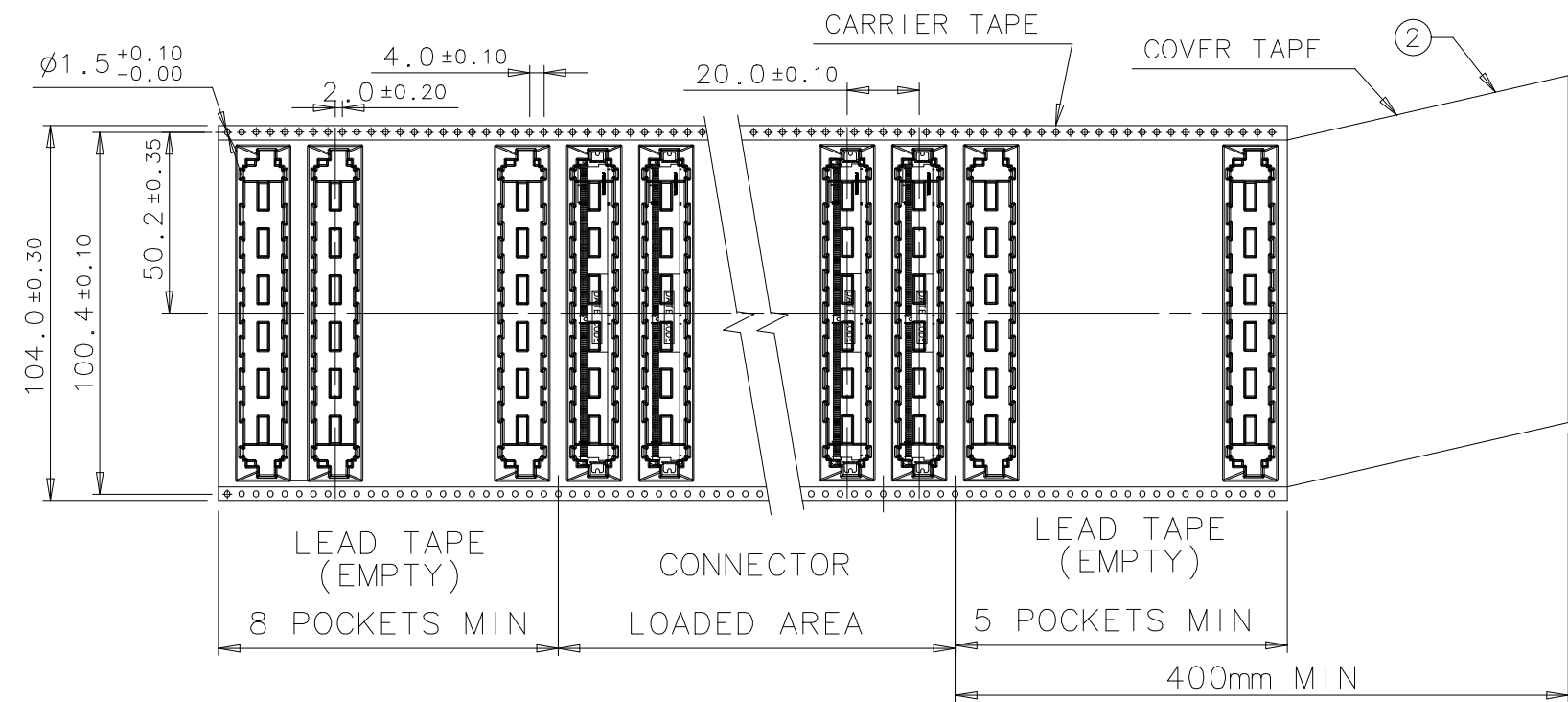

FEEDING DIRECTION

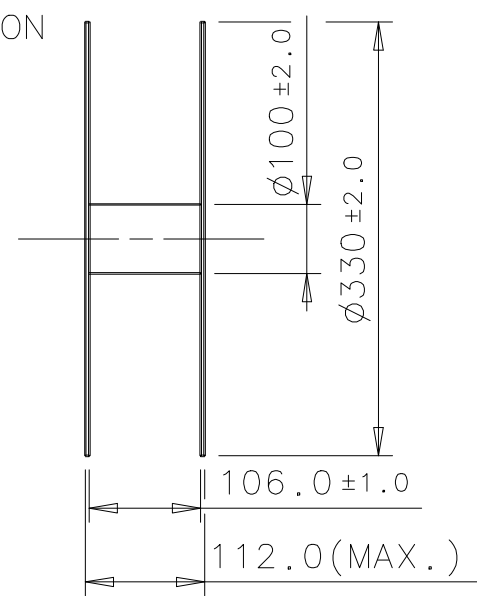

BC-17-0042095

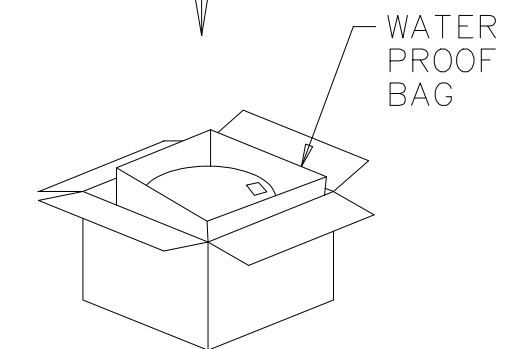
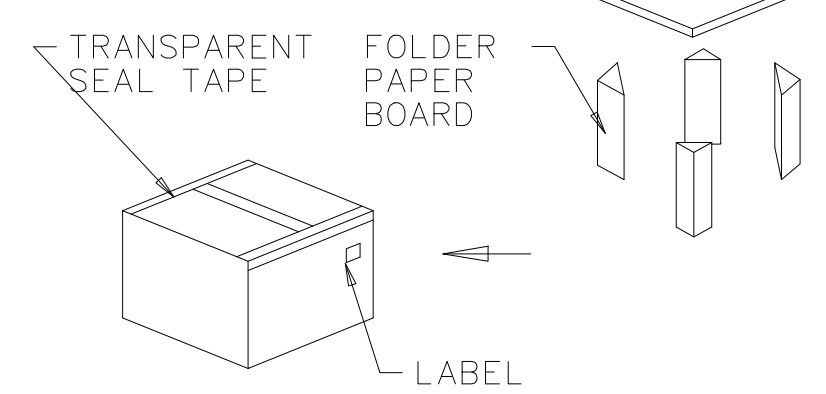

NOTES:

- 10 POCKETS HOLE PITCH CUMULATIVE TOLERANCE  $\pm 0.20\text{mm}$ .
- COVER TAPE PEELING STRENGTH : 0.01kgf MIN., 0.15 kgf MAX. AT 300mm/min.

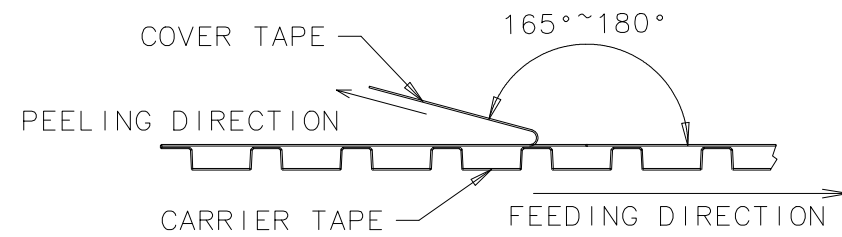

- PACKING CAPACITY : 600 PCS/REEL, 3 REELS/BOX, TOTAL 1800 PCS/BOX.

|      |              |             |
|------|--------------|-------------|
| ③    | REEL         | POLYSTYRENE |
| ②    | COVER TAPE   | POLYESTER   |
| ①    | CARRIER TAPE | POLYSTYRENE |
| ITEM | DESCRIPTION  | MATERIAL    |

|   |                     |          |                         |  |       |       |      |     |     |   |
|---|---------------------|----------|-------------------------|--|-------|-------|------|-----|-----|---|
| X. $\pm 1.0$  | X°. $\pm 2.0^\circ$ | UNITS mm | NAME (INTENDED USE)     | <b>FOXCONN INTERCONNECT TECHNOLOGY LIMITED.</b>  |       |       |      |     |     |   |
| .X $\pm 0.50$   | .X° $\pm 1.0^\circ$ | MAT'L    | MXM 3.0 CONNECTOR       |  |       |       |      |     |     |   |
| .XX $\pm 0.20$  | .XX°                | FINISH   | PART NO. (INTENDED USE) | CLASS:<br><input type="checkbox"/> CONFIDENTIAL <input type="checkbox"/> SECRET <input checked="" type="checkbox"/> GENERAL        |       |       |      |     |     |   |
| .XXX $\pm$  | .XXX° $\pm$         |          | ASOB82*-S43*-H          | TITLE: CUSTOMER DRAWING  |       |       |      |     |     |   |
| THESE DRAWINGS AND SPECIFICATIONS ARE THE PROPERTY OF FOXCONN INTERCONNECT TECHNOLOGY LIMITED AND SHALL NOT BE REPRODUCED, COPIED OR USED IN ANY MANNER WITHOUT THE PRIOR WRITTEN CONSENT OF FOXCONN INTERCONNECT TECHNOLOGY LIMITED. |                     |          | APPD: Davy Bu           | DWG NO.:   |       |       |      |     |     |   |
|   |                     |          | CHKD: Johnny Tang       | 317-0000-1659  |       |       |      |     |     |   |
|   |                     |          | DR: Eric.y.s 03/01'18   | <table border="1"> <tr> <td>SCALE</td> <td>SHEET</td> <td>REV.</td> </tr> <tr> <td>N/A</td> <td>4/4</td> <td>F</td> </tr> </table> | SCALE | SHEET | REV. | N/A | 4/4 | F |
| SCALE   | SHEET               | REV.     |                         |  |       |       |      |     |     |   |
| N/A   | 4/4                 | F        |                         |  |       |       |      |     |     |   |

CONNECTOR P/N ASOB82\*-S43\*-7H