

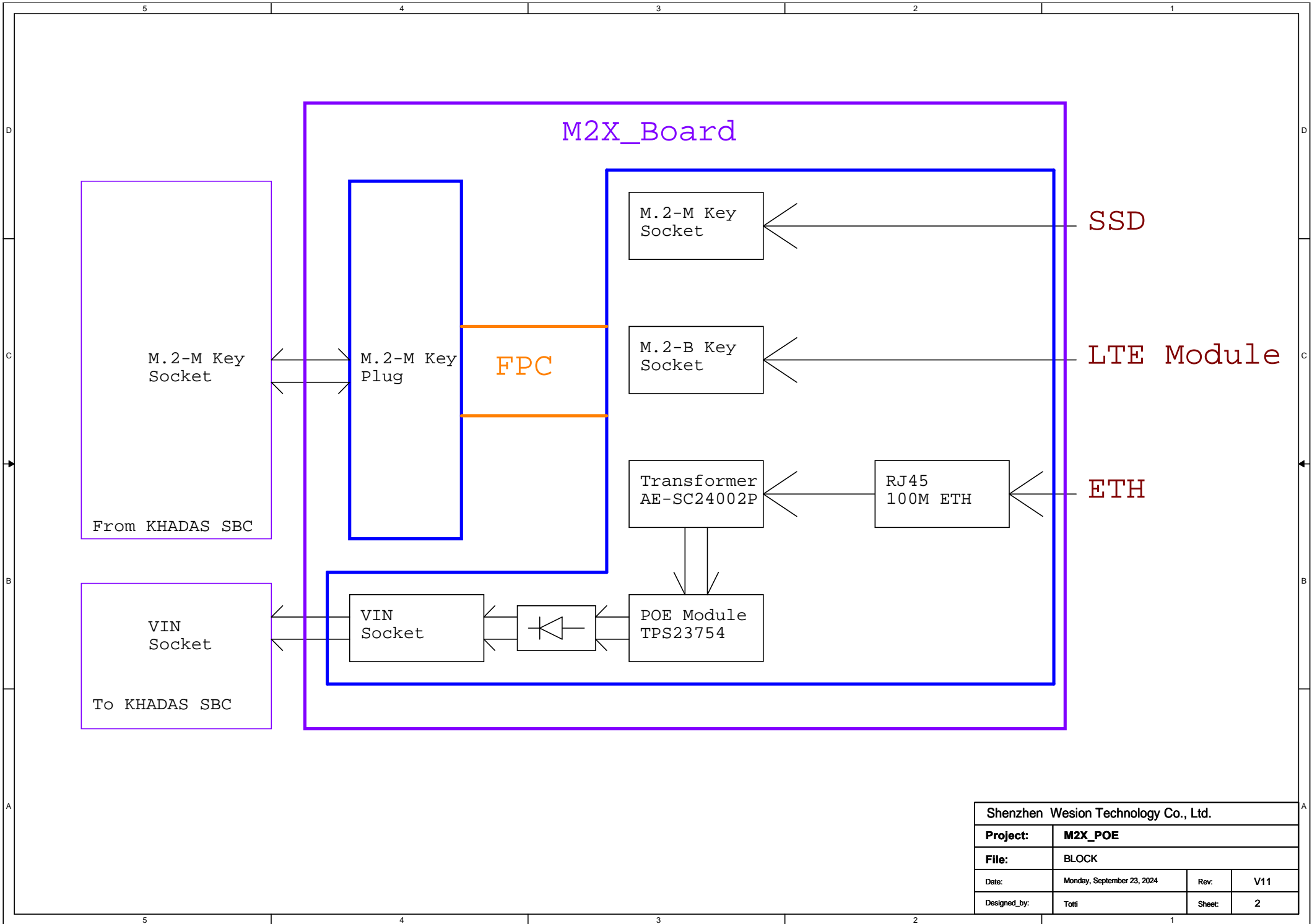

KHADASS

Something a little different.

| | | | |
|--------------------------------------|----------------------------|---------------|-----|
| Shenzhen Wesion Technology Co., Ltd. | | | |
| Project: | M2X_POE | | |
| File: | Khadass | | |
| Date: | Thursday, October 20, 2022 | Rev: | V11 |
| Designed_by: | Totti | Sheet: | 1 |



| | | | |
|--------------------------------------|----------------------------|---------------|-----|
| Shenzhen Wesion Technology Co., Ltd. | | | |
| Project: | M2X_POE | | |
| File: | BLOCK | | |
| Date: | Monday, September 23, 2024 | Rev: | V11 |
| Designed_by: | Totti | Sheet: | 2 |

M-KEY socket

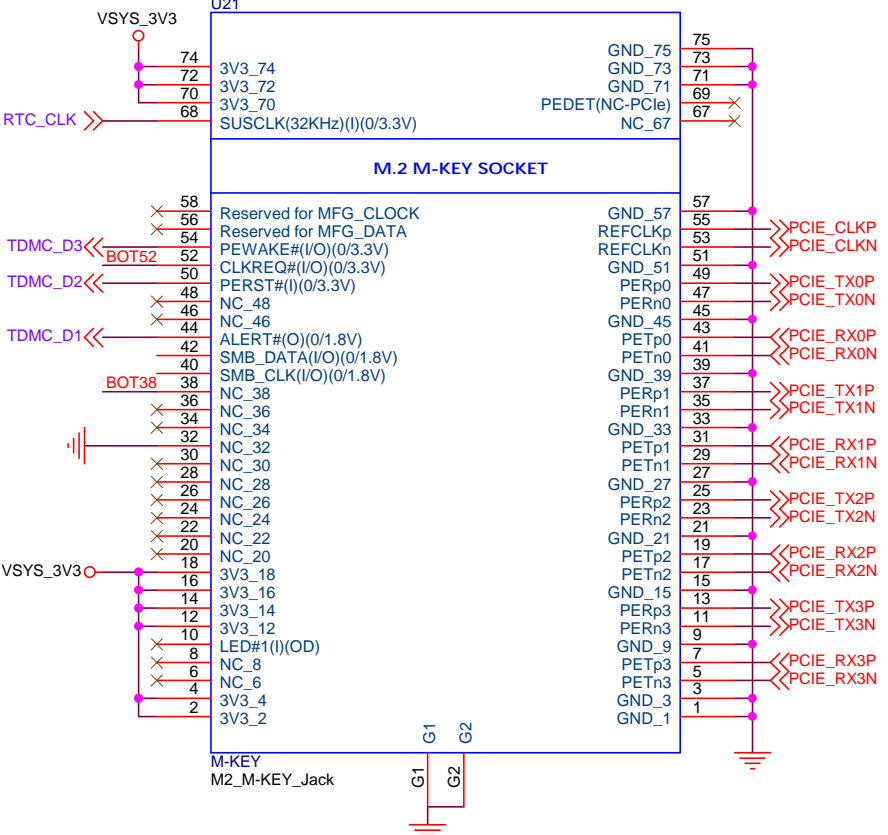

FROM KHADAS SBC

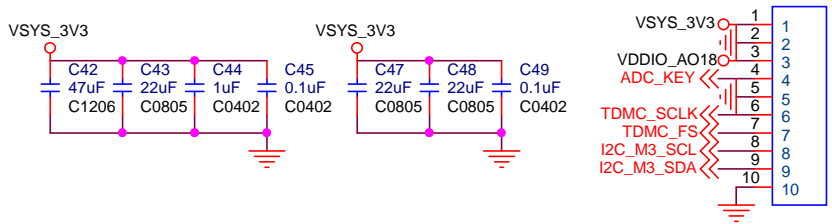
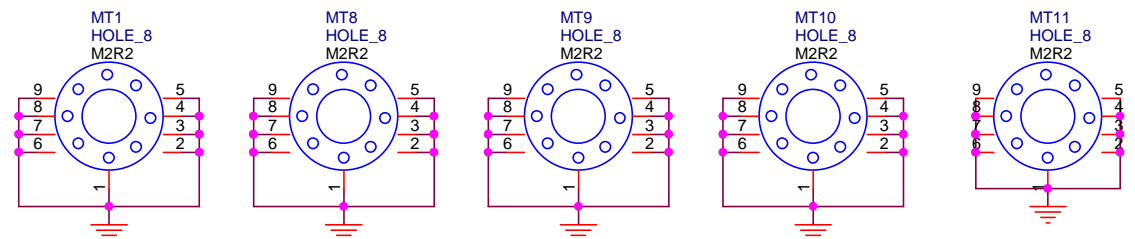
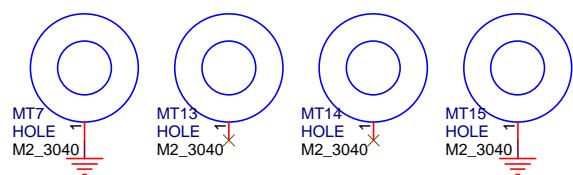
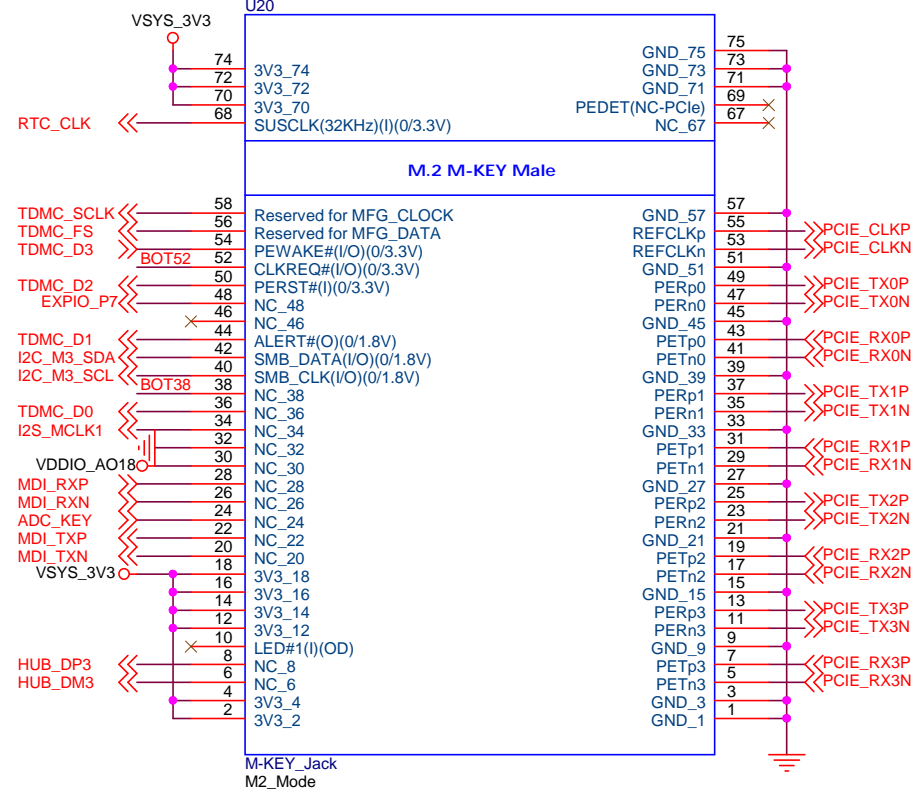

| | | | |
|--------------------------------------|-----------------------------|---------------|-----|
| Shenzhen Wesion Technology Co., Ltd. | | | |
| Project: | M2X_POE | | |
| File: | PCIe-IO | | |
| Date: | Tuesday, September 24, 2024 | Rev: | V11 |
| Designed_by: | Totti | Sheet: | 3 |

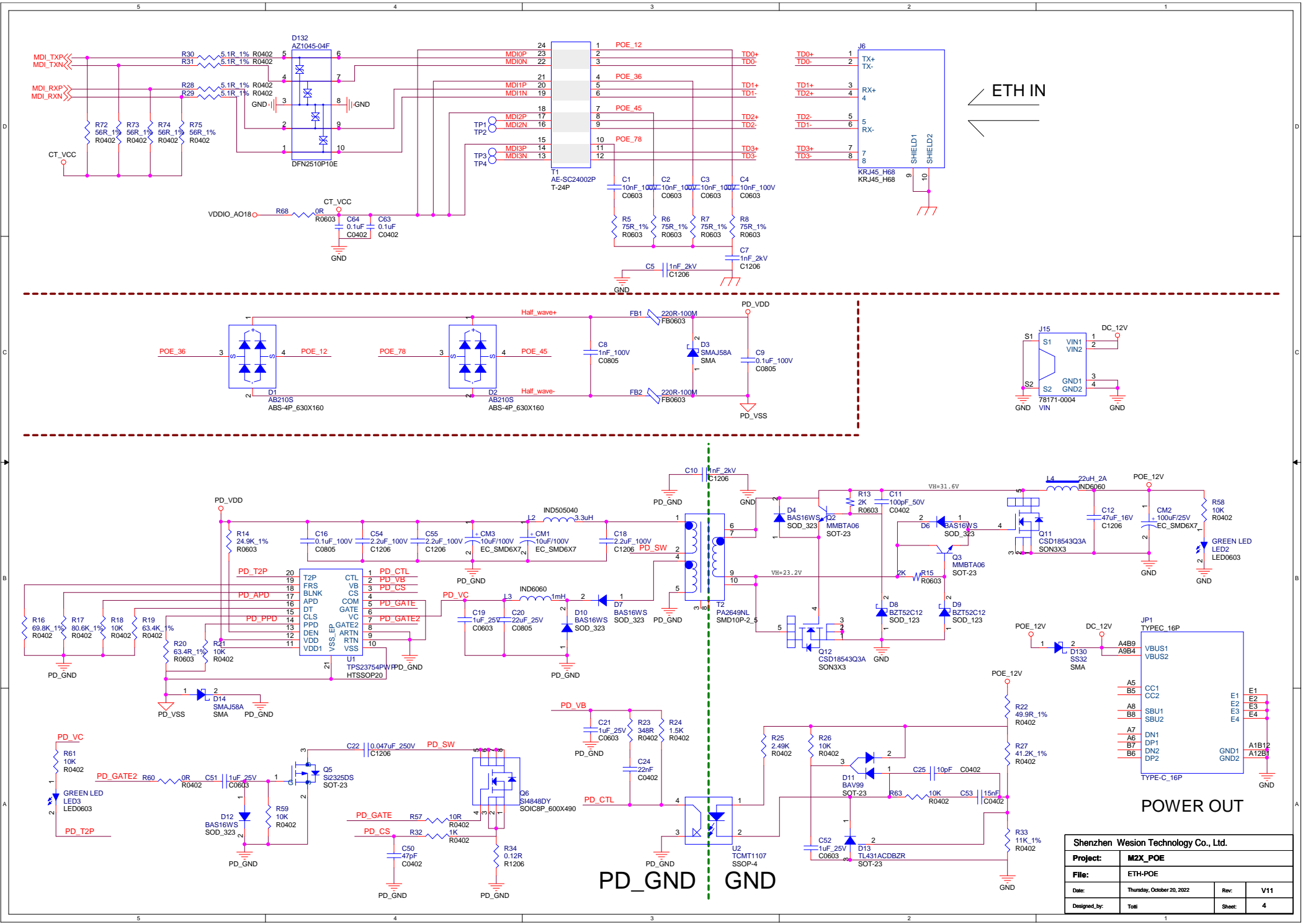

| | | | |
|--------------------------------------|----------------------------|--------|-----|
| Shenzhen Wesion Technology Co., Ltd. | | | |
| Project: | M2X_POE | | |
| File: | ETH-POE | | |
| Date: | Thursday, October 20, 2022 | Rev: | V11 |
| Designed_by: | Toni | Sheet: | 4 |

LTE POWER

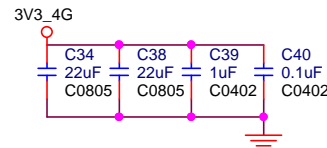
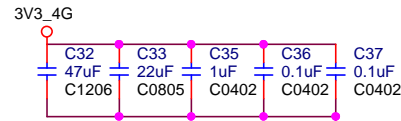
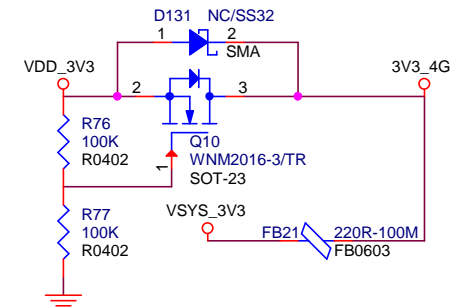
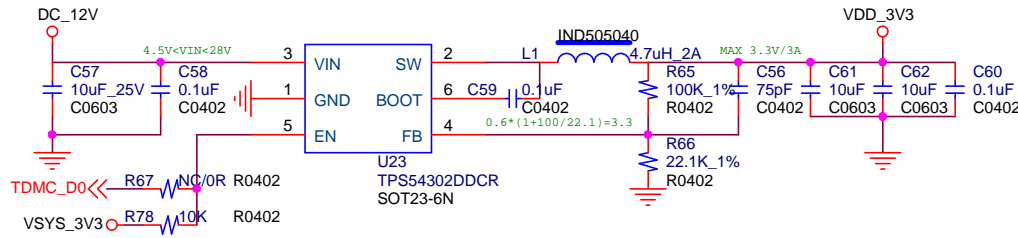

When this pin active low, 4G module wake up the host

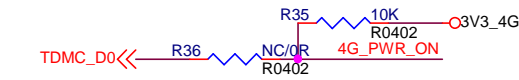

Now: powered on automatically



Now: no reset

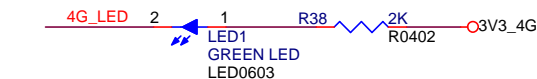

LTE

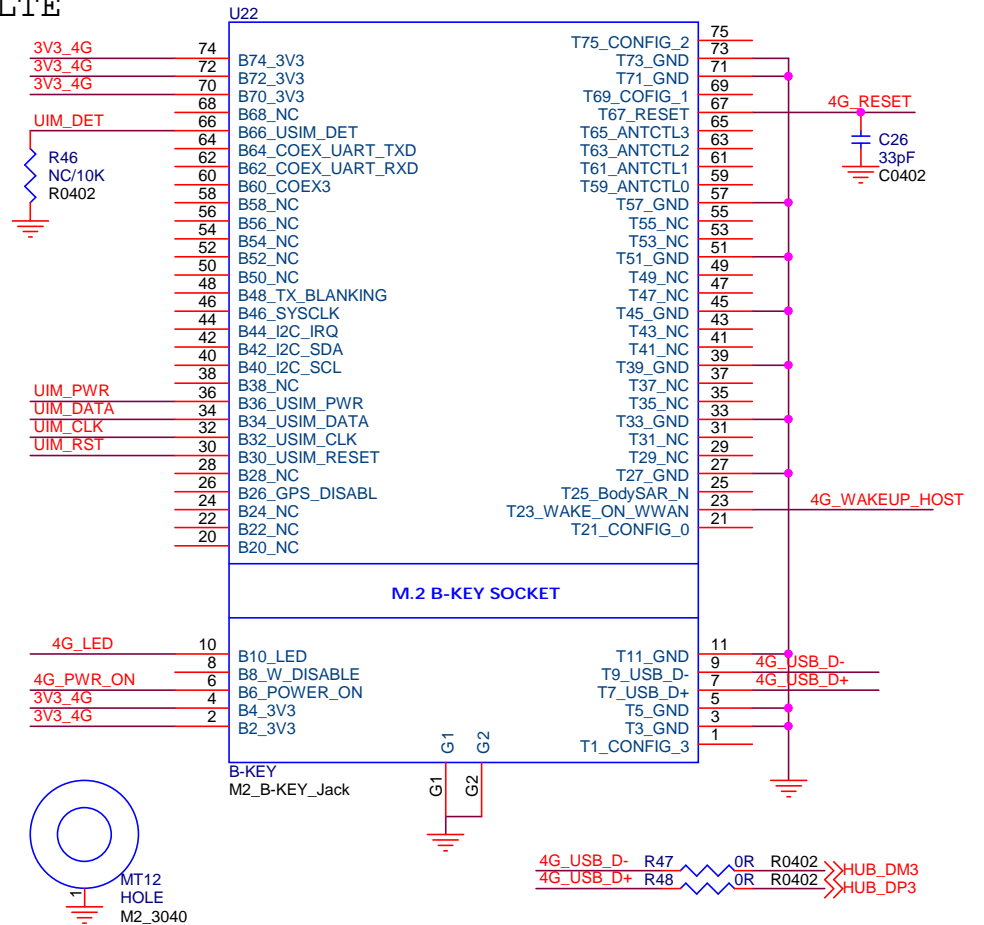

Nano SIM card

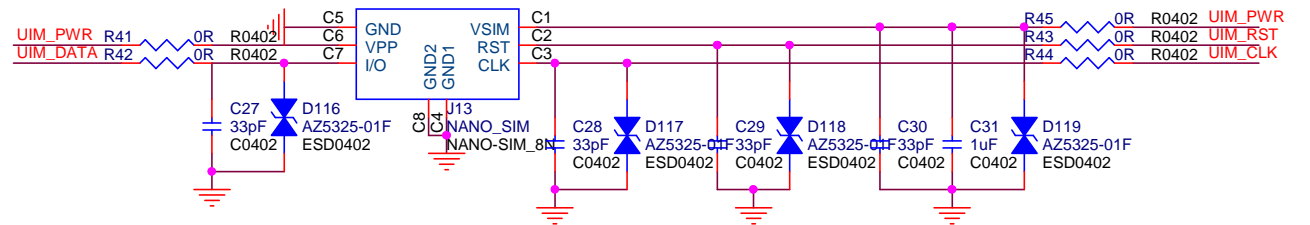

| | | | |
|--------------------------------------|----------------------------|--------|-----|
| Shenzhen Wesion Technology Co., Ltd. | | | |
| Project: | M2X_POE | | |
| File: | LTE-M2 | | |
| Date: | Monday, September 23, 2024 | Rev: | V11 |
| Designed_by: | Totti | Sheet: | 5 |