

LED Power 3mA



KHADASS

Something a little different.

Shenzhen Wesion Technology Co., Ltd.

Project: VIM3

File: Khadas

Date: Saturday, November 07, 2020

Rev: V13

Designed by: Gouwa

Sheet: 1 of 11

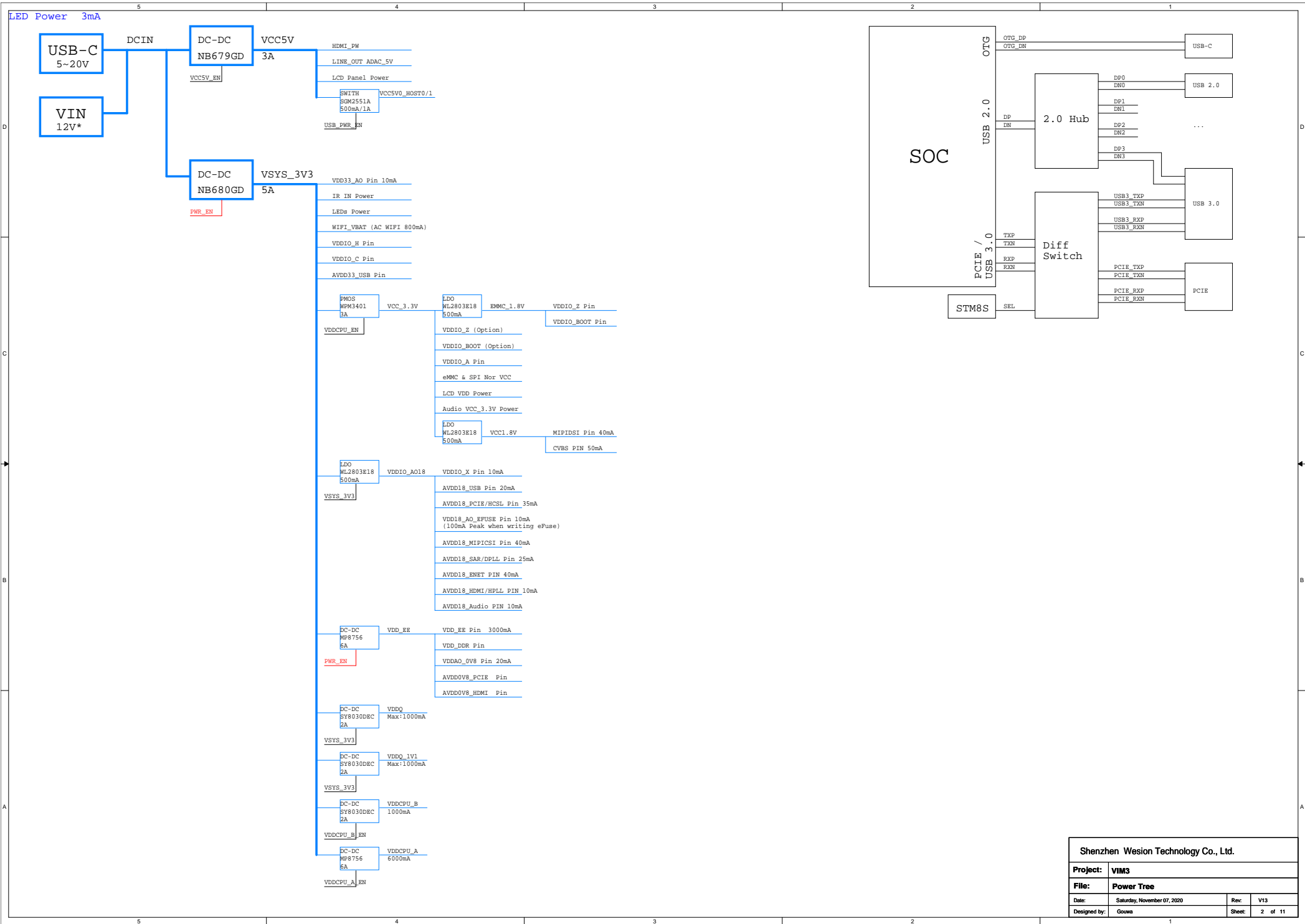

Shenzhen Wesion Technology Co., Ltd.			
Project:	VIM3		
File:	Power Tree		
Date:	Saturday, November 07, 2020	Rec:	V13
Designed by:	Gouwa	Sheet:	2 of 11

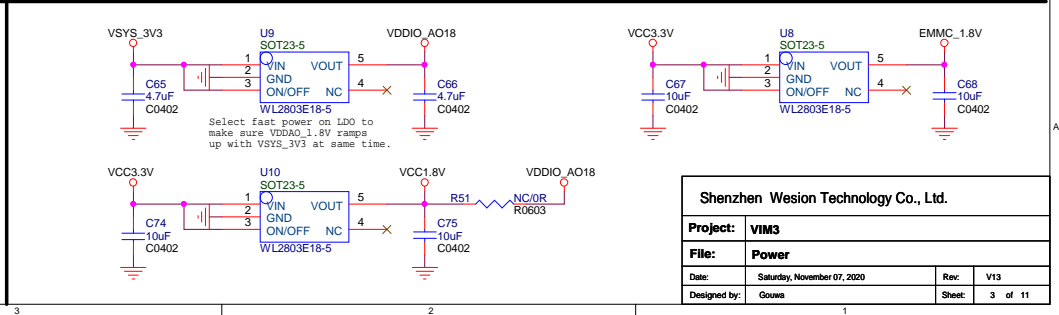
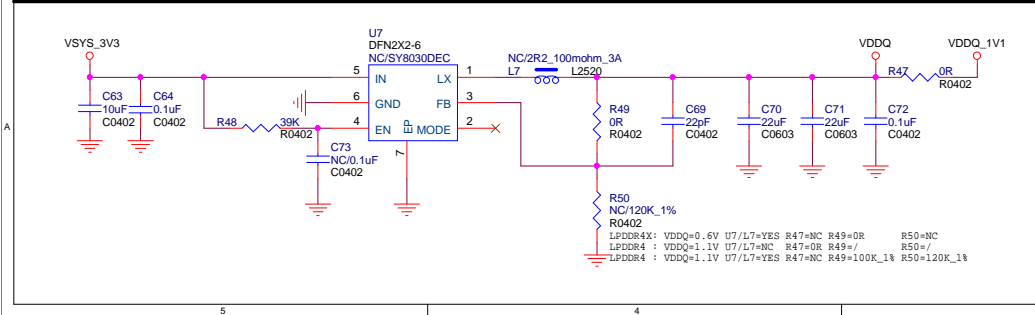
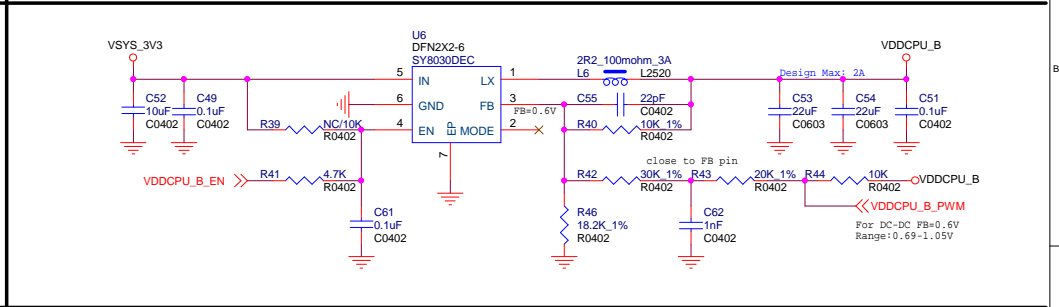
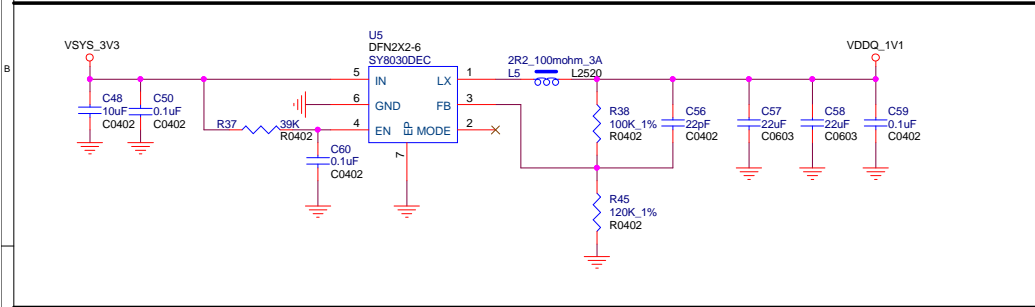
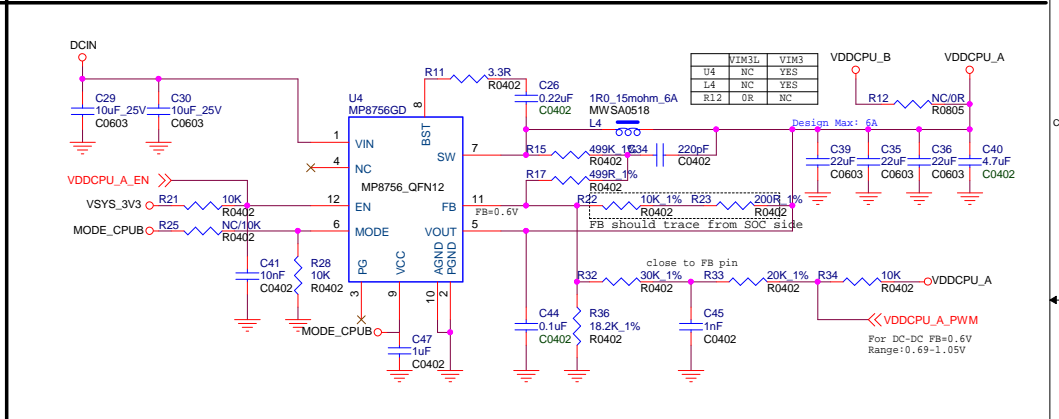
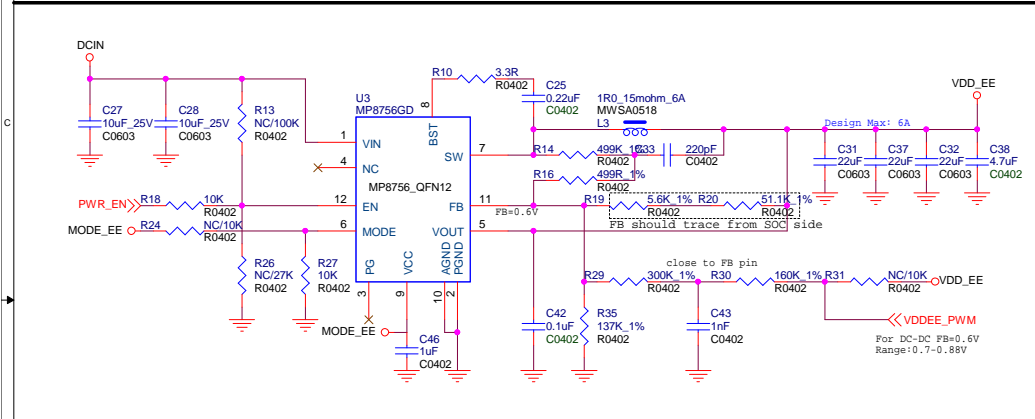
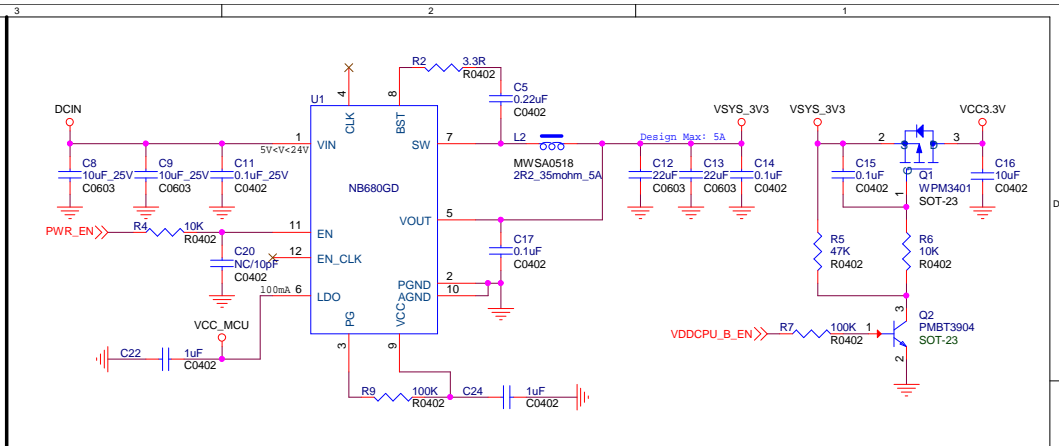
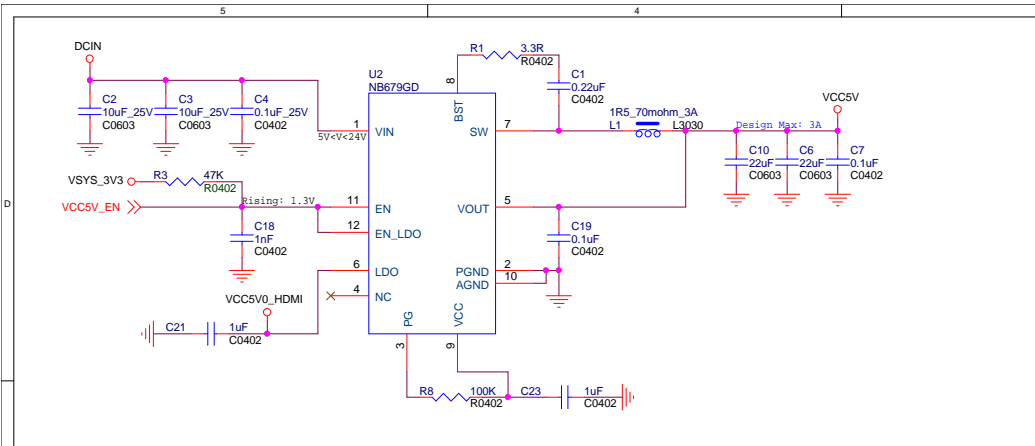

Shenzhen Wesion Technology Co., Ltd.			
Project:	VIM3		
File:	Power		
Date:	Saturday, November 07, 2020	Rec:	V13
Designed by:	Gouwa	Sheet:	3 of 11

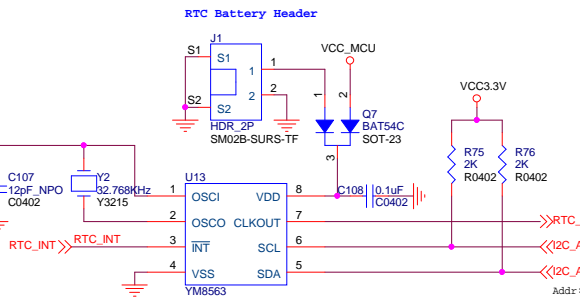
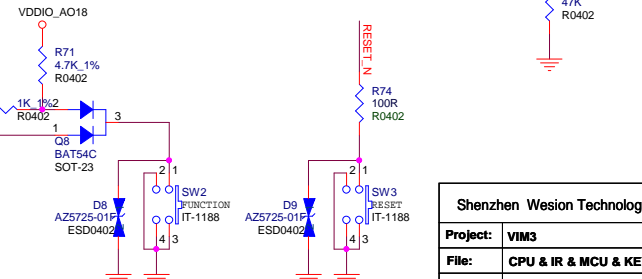
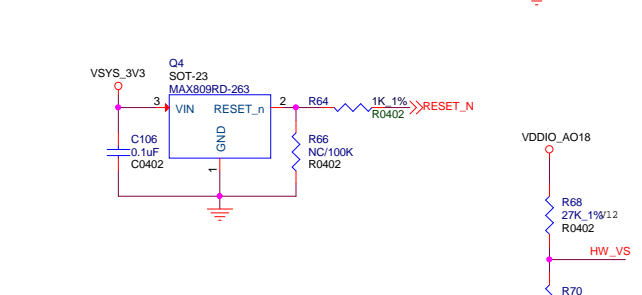
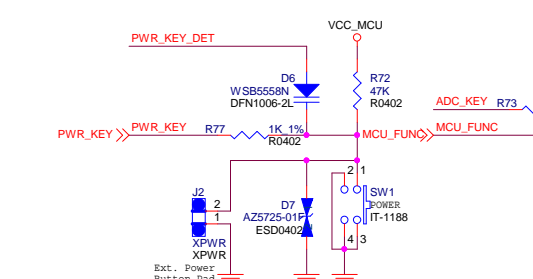
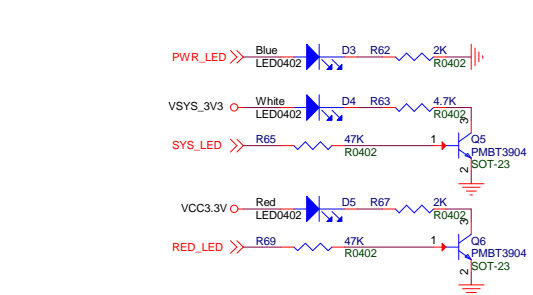
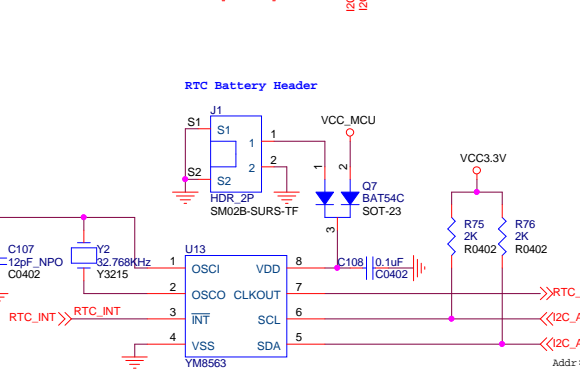
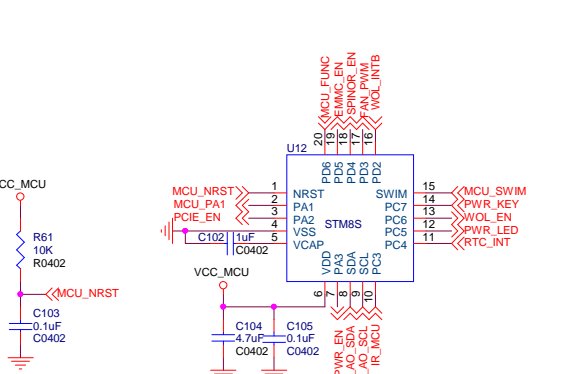
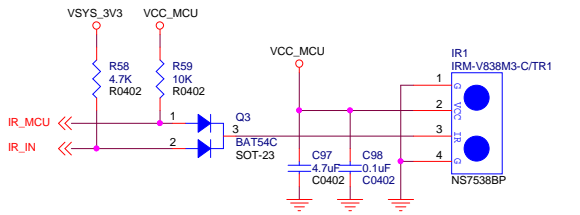
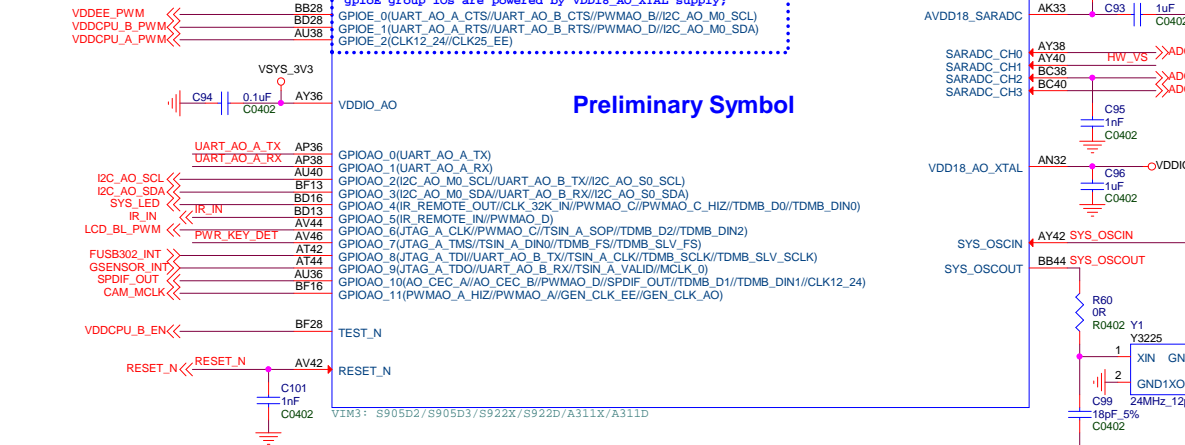
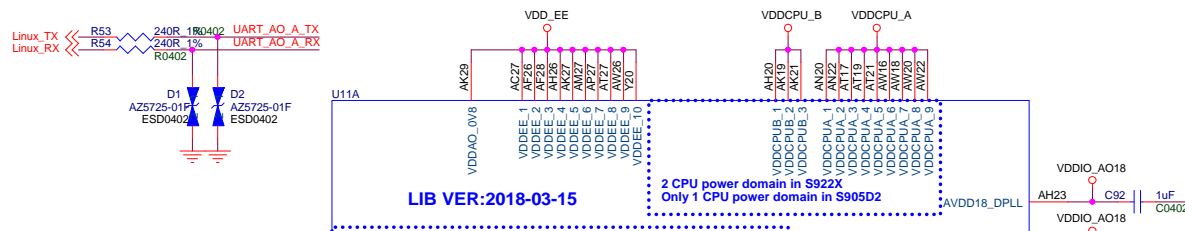
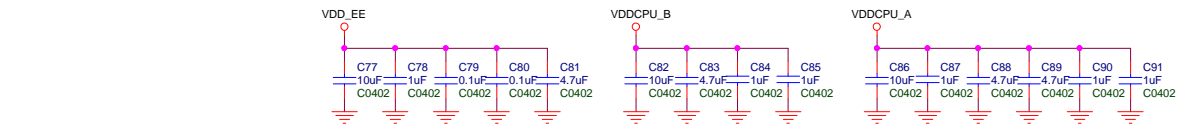
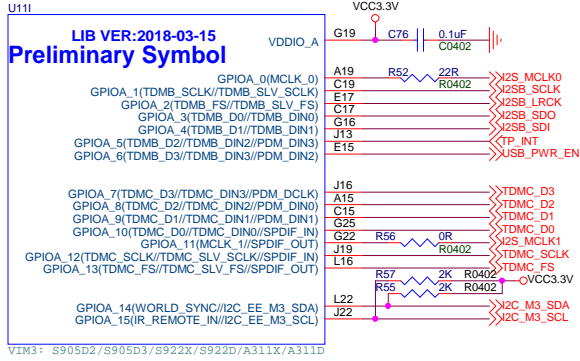

Shenzhen Wesion Technology Co., Ltd.			
Project: VIM3			
File: CPU & IR & MCU & KEYS			
Date: Saturday, November 07, 2020	Rec:	V13	
Designed by: Gouwa	Sheet:	4 of 11	

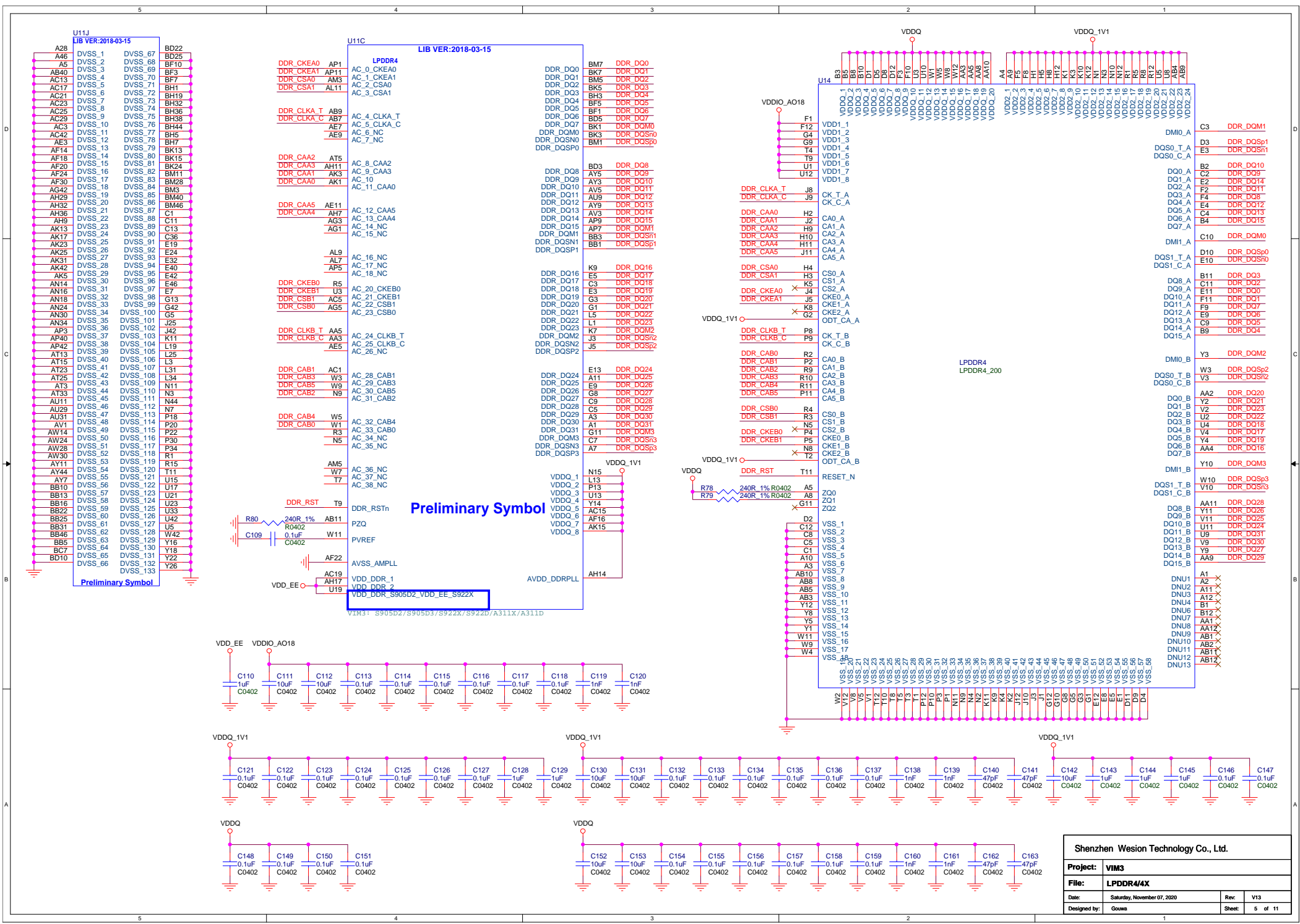

Shenzhen Wesion Technology Co., Ltd.			
Project:	VIM3		
File:	LPDDR4/4X		
Date:	Saturday, November 07, 2020	Rec:	V13
Designed by:	Gouwa	Sheet:	5 of 11

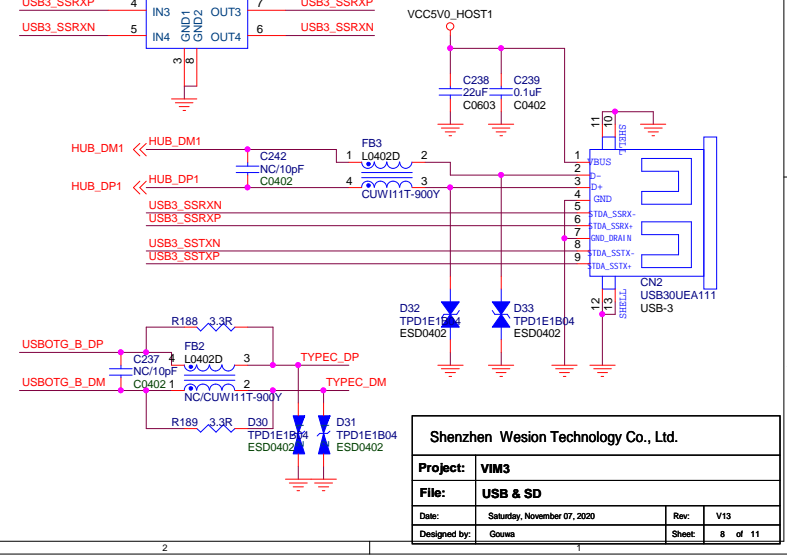
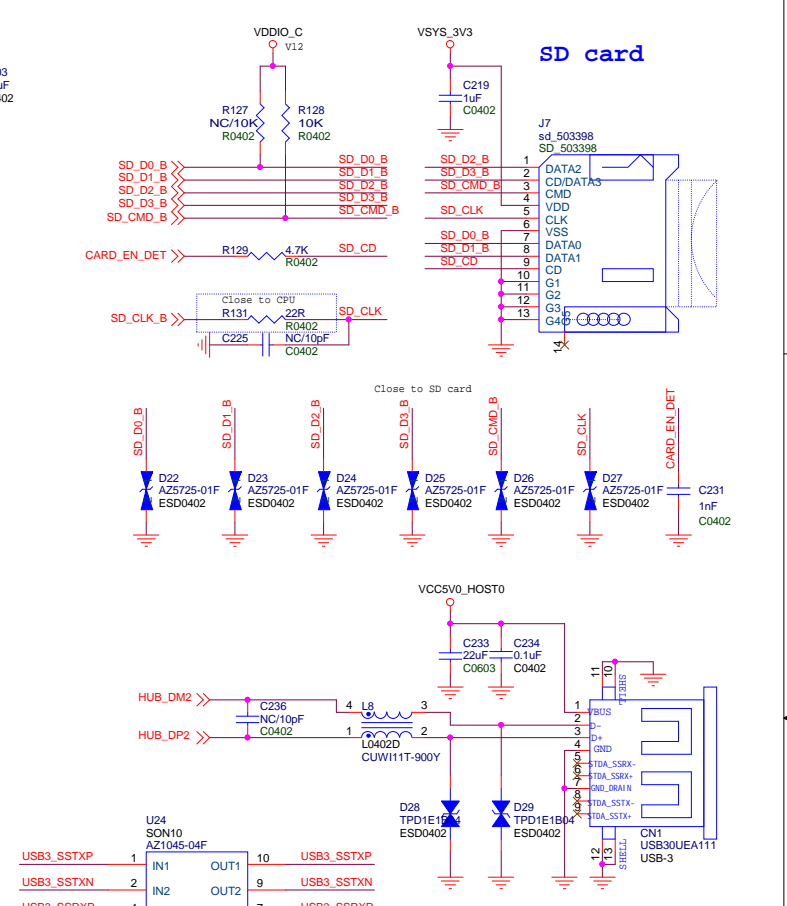
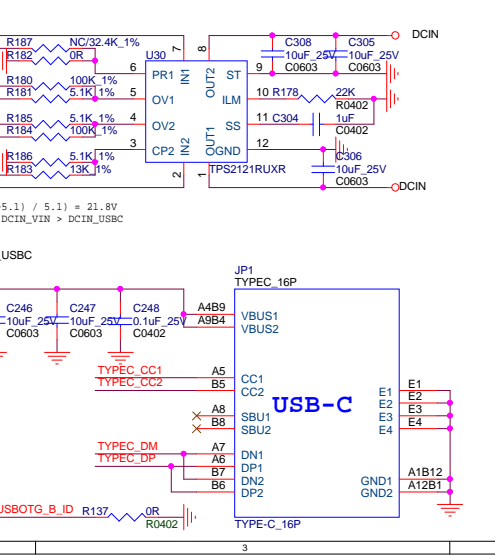
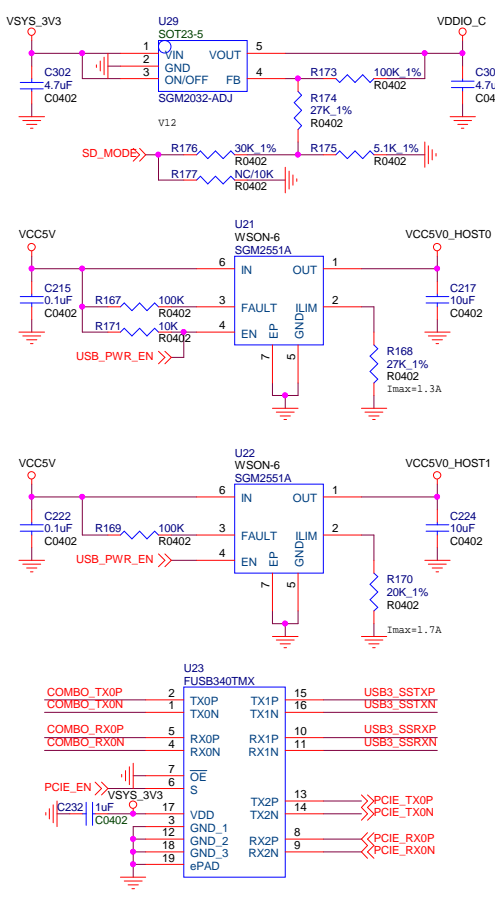
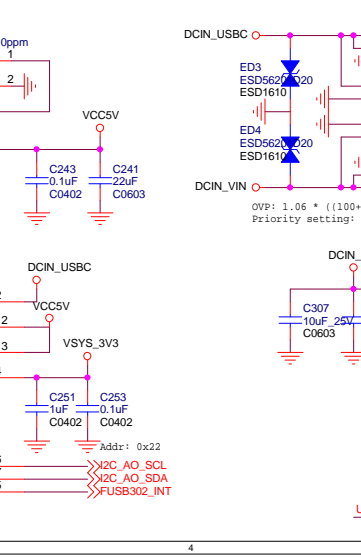
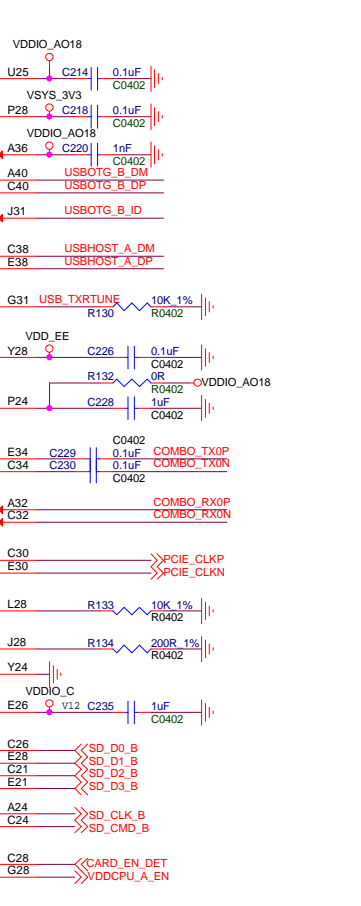
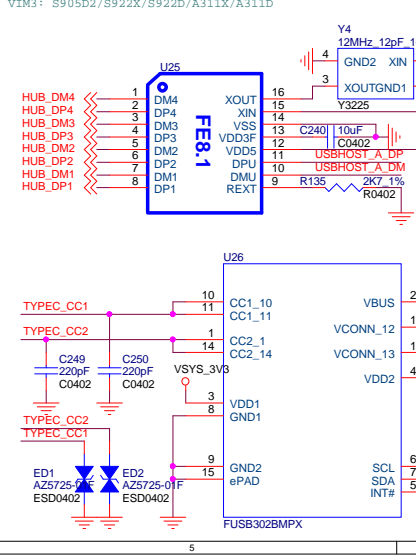
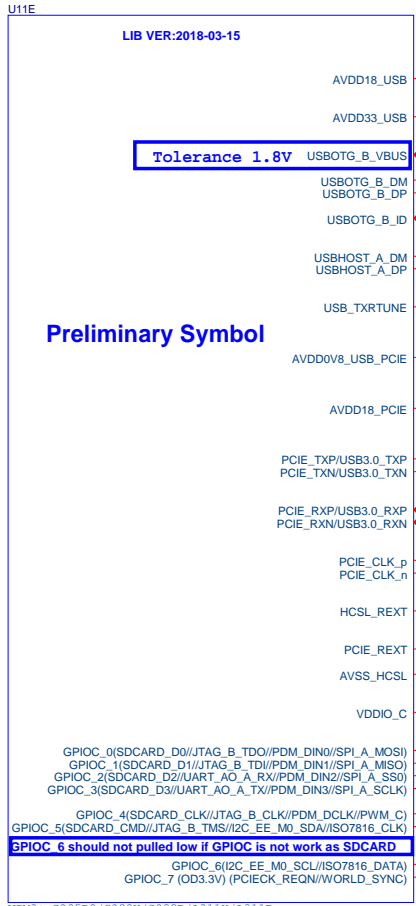

Shenzhen Wesion Technology Co., Ltd.			
Project:	VIM3		
File:	USB & SD		
Date:	Saturday, November 07, 2020	Rev:	V13
Designed by:	Gouwa	Sheet:	8 of 11

LIB VER:2018-03-15

Preliminary Symbol

VDDIO_X

GPIOX_0(SDIO_D0/PDM_DIN0/TSIN_A_DIN0)
 GPIOX_1(SDIO_D1/PDM_DIN1/TSIN_A_SOP)
 GPIOX_2(SDIO_D2/PDM_DIN2/TSIN_A_VALID)
 GPIOX_3(SDIO_D3/PDM_DIN3/TSIN_A_CLK/PWM_D)
 GPIOX_4(SDIO_CLK/PDM_DCLK)
 GPIOX_5(SDIO_CMD/MCLK_1/PWM_C)

GPIOX_6(PWM_A/UART_EE_B_TX/PWM_D)
 GPIOX_7(PWM_F/UART_EE_B_RX/PWM_B)

GPIOX_8(TDMA_D1/TDMA_DIN1/TSIN_B_SOP/SPI_A_MOSI/ISO7816_CLK/PWM_C)
 GPIOX_9(TDMA_D0/TDMA_DIN0/TSIN_B_VALID/SPI_A_MISO/ISO7816_DATA)
 GPIOX_10(TDMA_FS/TDMA_SLV_FS/TSIN_B_DIN0/SPI_A_SS0/I2C_EE_M1_SDA)
 GPIOX_11(TDMA_SCLK/TDMA_SLV_SCLK/TSIN_B_CLK/SPI_A_SCLK/I2C_EE_M1_SCL)
 GPIOX_12(UART_EE_A_TX)
 GPIOX_13(UART_EE_A_RX)
 GPIOX_14(UART_EE_A_CTS)
 GPIOX_15(UART_EE_A_RTS)

GPIOX_16(PWM_E)
 GPIOX_17(I2C_EE_M2_SDA)
 GPIOX_18(I2C_EE_M2_SCL)
 GPIOX_19(PWM_B/WORLD_SYNC/GEN_CLK_EE)

GPIOX_0: WIFI_SD_D0
 GPIOX_1: WIFI_SD_D1
 GPIOX_2: WIFI_SD_D2
 GPIOX_3: WIFI_SD_D3
 GPIOX_4: WIFI_SD_CLK
 GPIOX_5: WIFI_SD_CMD
 GPIOX_6: WIFI_PWREN
 GPIOX_7: WIFI_WAKE_HOST
 GPIOX_8: BTPCM_DIN
 GPIOX_9: BTPCM_DOUT
 GPIOX_10: BTPCM_SYNC
 GPIOX_11: BTUART_CLK
 GPIOX_12: BTUART_TX
 GPIOX_13: BTUART_RX
 GPIOX_14: BTUART_CTS_N
 GPIOX_15: BTUART_RTS_N
 GPIOX_16: WIFI_32K
 GPIOX_17: BT_EN
 GPIOX_18: BT_WAKE_HOST
 GPIOX_19: HOST_WAKE_BT

VIM3: S905D2/S905D3/S922X/S922D/A311X/A311D

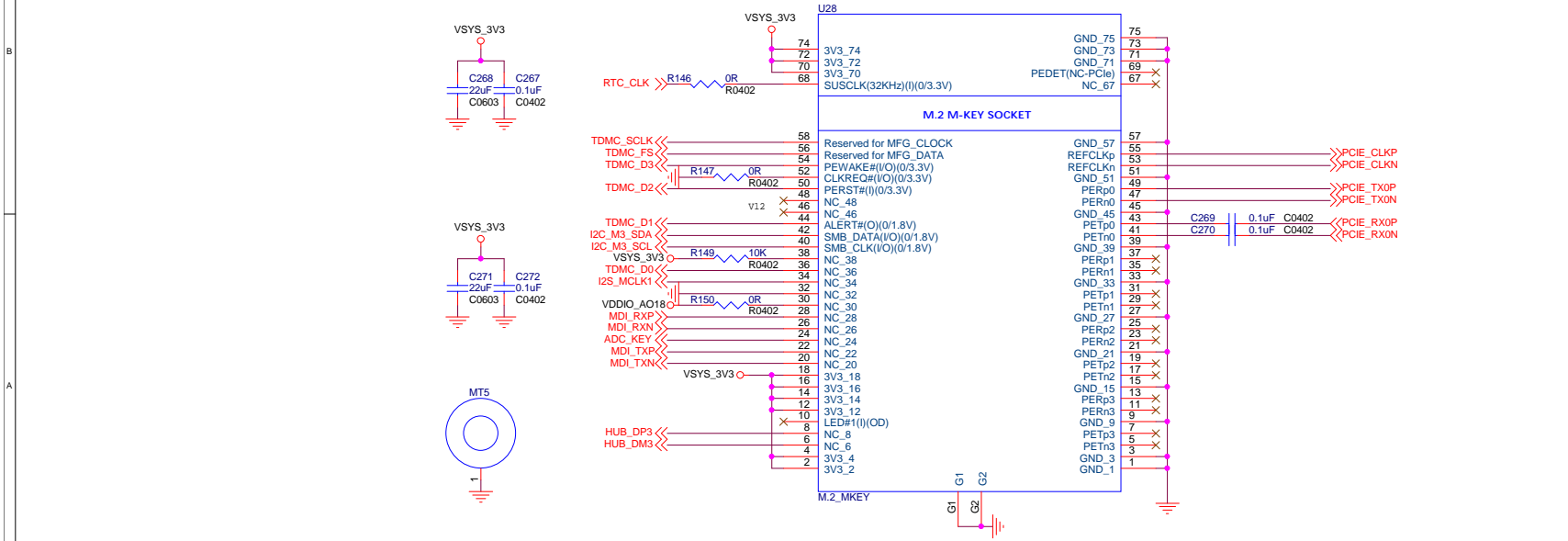
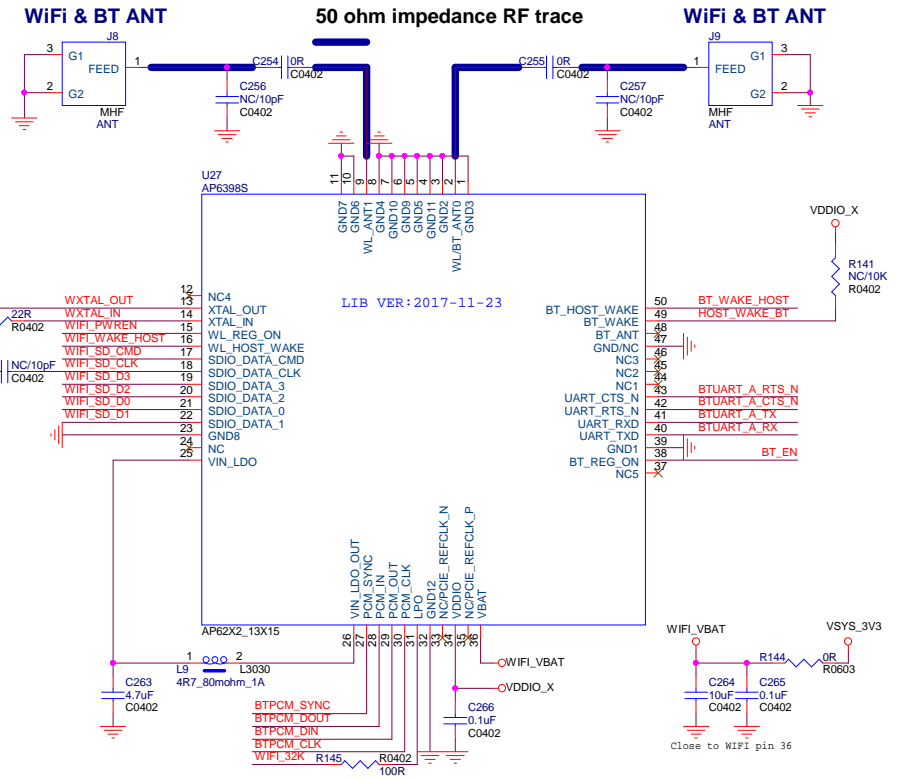

Shenzhen Wesion Technology Co., Ltd.

Project:	VIM3
File:	WiFi & BT & PCIE
Date:	Saturday, November 07, 2020
Designed by:	Gouwa
Rec:	V13
Sheet:	9 of 11

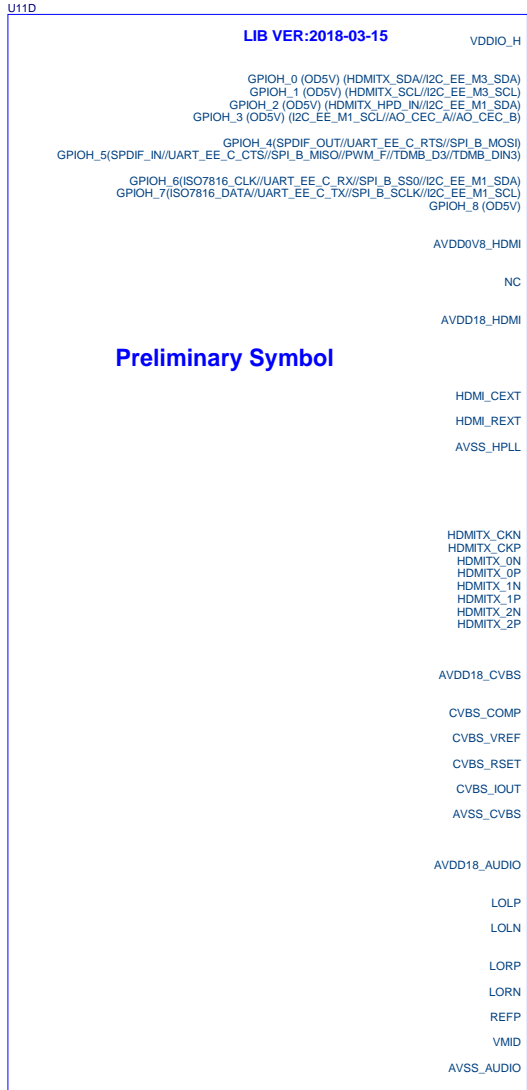

VIM3: S905D2/S905D3/S922X/S922D/A311X/A311D

HDMI output

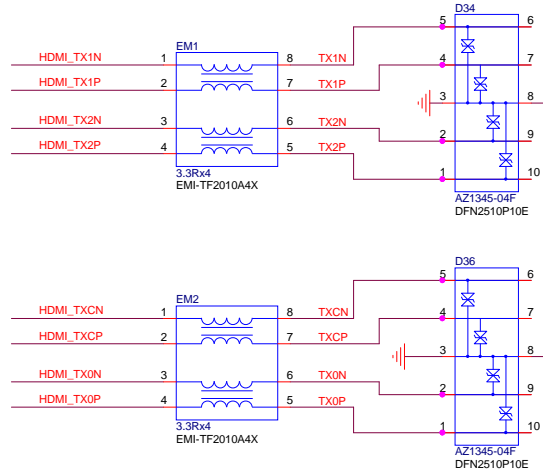

Type A

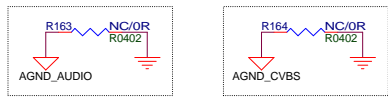
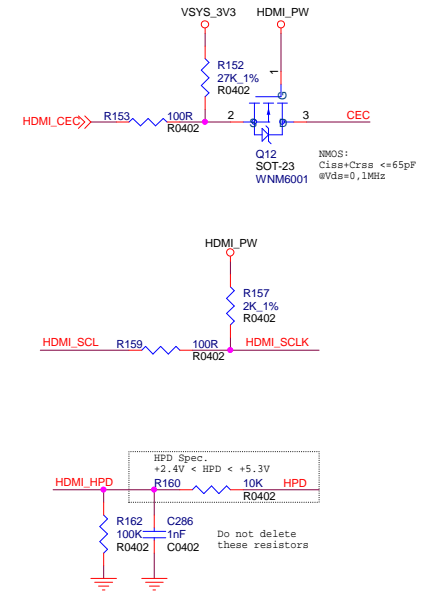
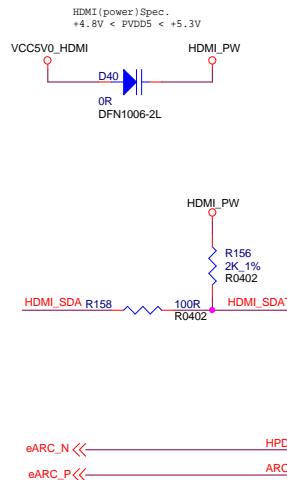
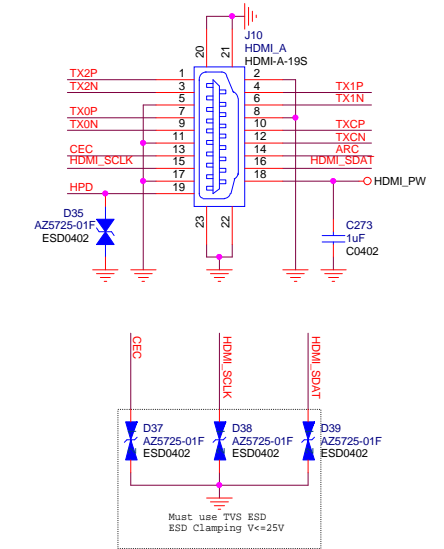

Shenzhen Wesion Technology Co., Ltd.			
Project:	VIM3		
File:	HDMI & CVBS		
Date:	Saturday, November 07, 2020	Rec:	V13
Designed by:	Gouwa	Sheet:	10 of 11

U11H
LIB VER:2018-03-15
Preliminary Symbol

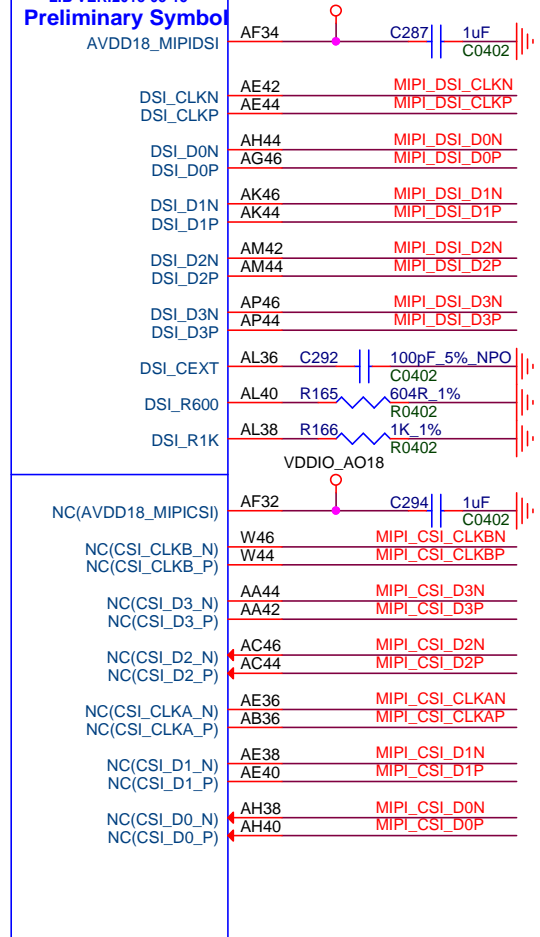

VIM3: S905D2/S905D3
S922X/S922D/
A311X/A311D

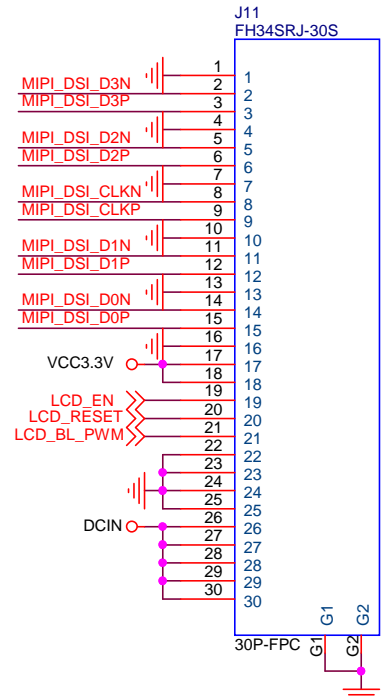
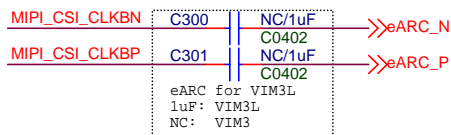

MIPI-DSI

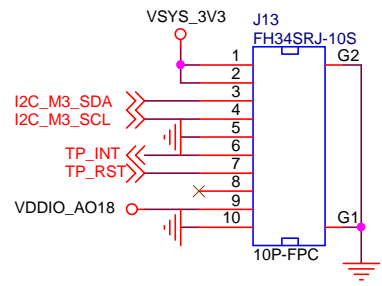

TP

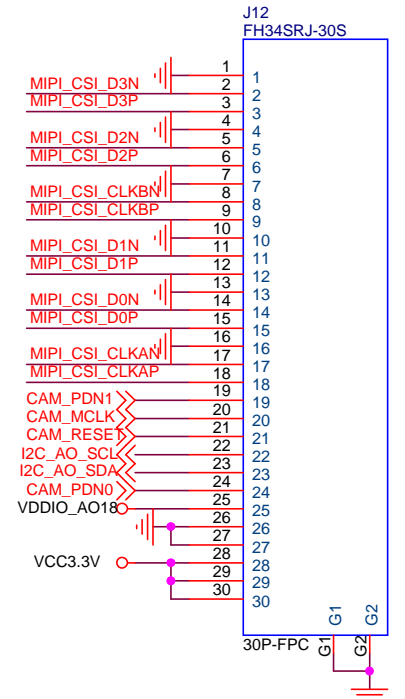
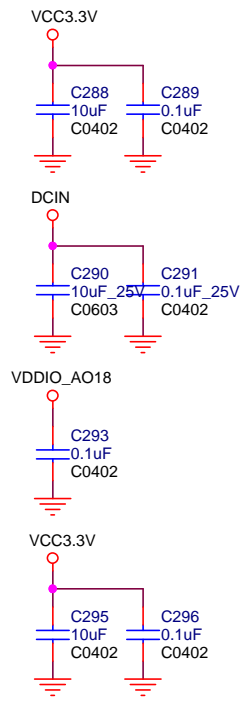

Camera0

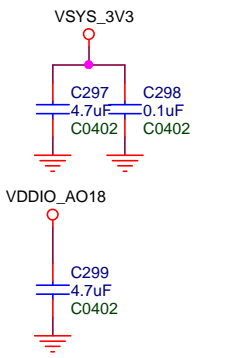

Shenzhen Wesion Technology Co., Ltd.			
Project:	VIM3		
File:	MIPI		
Date:	Saturday, November 07, 2020	Rev:	V13
Designed by:	Gouwa	Sheet:	11 of 11